

Parts Manual Manuel de pièces Manual de piezas

200-2344

Revision C

 *English* Oilless, Single Stage, Direct Drive, Electric Air Compressor

 *French* Sans l'huile, d'un seule étape, à prise directe, compresseur d'air électrique

 *Spanish* Sin aceite, de una sola etapa, de mando directo, compresor de aire eléctrico

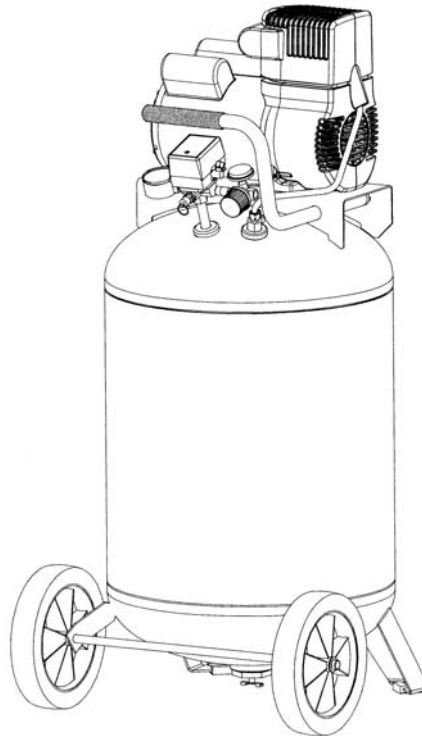

Specification Chart _____ Tableau des spécifications _____ Cuadro de especificaciones

MODEL NO. (MODÈLE) (MODELO)	PEAK H.P. (CV)	TANK CAPACITY GALLONS (CAPACITÉ DU RÉSERVOIR - LITRES) (CAPACIDAD DEL TANQUE - LITROS)	VOLTAGE/ AMPS/PHASE (TENSION/ AMPS/PHASE) (VOLTAJE AMP/FASE)	KICK-IN PRESSURE (PRESSION D'OUVERTURE) (PRESION DE CONEXION)	KICK-OUT PRESSURE (PRESSION DE FERM.) (PRESION DE DESCONEXION)
LAC631112	2	11 (42)	120/15/1	125 (8,6 bar)	155 (10,7 bar)
LA0501512	5	15 (57)	120/15/1	125 (8,6 bar)	155 (10,7 bar)
LA0602112	6	21 (79)	120/15/1	125 (8,6 bar)	155 (10,7 bar)
LA0602712	6	27 (102)	120/15/1	125 (8,6 bar)	155 (10,7 bar)
LA0603012	6	30 (114)	120/15/1	125 (8,6 bar)	155 (10,7 bar)



Questions? See back page. _____ Questions ? Consultez la page final. _____ ¿Preguntas? Vea la página final.

PARTS DRAWING / DESSIN DES PIÈCES / ESQUEMA DE LA PIEZAS

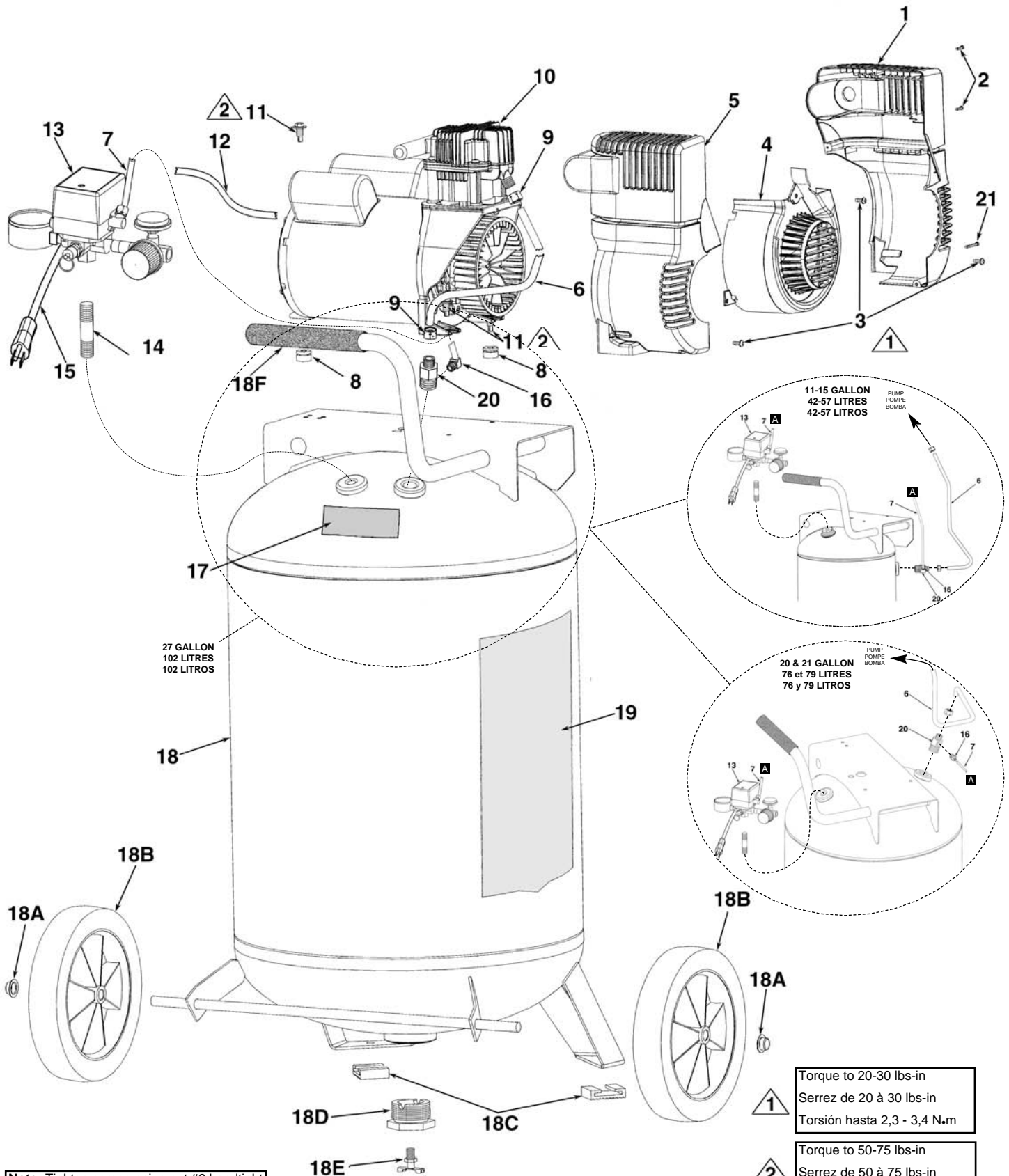



Note: Tighten compression nut #9 handtight plus 1 full turn.
Note: Serrez l'écrou #9 de compactage solide plus 1 plein tour.
Nota: Apriete la tuerca #9 de la compresión handtight más 1 vuelta completa.

Torque to 20-30 lbs-in
 Serrez de 20 à 30 lbs-in
 Torsión hasta 2,3 - 3,4 N.m

Torque to 50-75 lbs-in
 Serrez de 50 à 75 lbs-in
 Torsión hasta 5,7 - 8,5 N.m

Torque to 100-120 lbs-in
 Serrez de 100 à 120 lbs-in
 Torsión hasta 11,3 - 13,6 N.m

PARTS LIST / LISTE DE PIÈCES / LISTA DE LAS PIEZAS

Item Art Art	Part No N° / P Núm / P	Qty Qté Cant	 English <u>Description</u>	 French <u>Description</u>	 Spanish <u>Descripción</u>
1	142-0122	1	Shroud, left	Enveloppe	Guardera
2	N/A	2	Screw, plastite 4-20	Vis	Tornillo
3	N/A	3	Screw, #8-32 x 7/16" lg	Vis	Tornillo
4	142-0118	1	Shroud, scroll	Enveloppe	Guardera
5	142-0123	1	Shroud, right	Enveloppe	Guardera
6	145-0386	1	Transfer tube (11 Gal)	Tube	Tubo
or	145-0387	1	Transfer tube (15 Gal)	Tube	Tubo
or	145-0391	1	Transfer tube (20 & 21 Gal)	Tube	Tubo
or	145-0384	1	Transfer tube (27 Gal)	Tube	Tubo
7	145-0324	1	Bleeder tube	Tube	Tubo
8	093-0019	3	Grommet	Oeillet	Arandela de cabo
9	058-0007	2	Nut, 3/8" O.D. tube	Écrou	Tuerca
10	040-0328	1	Pump/motor assy (2 peak hp)	Ensemble pompe/moteur	Conjunto de bomba/motor
or	040-0326	1	Pump/motor assy (5&6 peak hp)	Ensemble pompe/moteur	Conjunto de bomba/motor
			<i>See pages 6 & 7</i>	<i>Voir les pages 6 et 7</i>	<i>Vea las paginaciones 6 y 7</i>
11	059-0221	3	Bolt, shoulder, 1/4-28	Boulon	Perno
12	026-0233	1	Interconnect cord	Câble	Cordón
13	See pages 4 & 5	1	Manifold assembly	Ensemble du collecteur	Conjunto de múltiple
14	N/A	1	Nipple, 1/4" NPT x 2-1/2"	Manchon fileté	Niple
15	026-0030	1	Power cord	Câble	Cordón
16	068-0506	1	Connector 1/8NPT X 1/4TB	Connecteur	Conector
17	098-2856	1	Label, warning	D'avertissement étiquette	Amonestadora escritura de la
18	153-0063	1	Tank assembly (11 gal)	Ensemble du réservoir,	Conjunto de tanque,
or	153-0062	1	Tank assembly (15 gal)	Ensemble du réservoir,	Conjunto de tanque,
or	153-0075	1	Tank assembly (20 & 21 gal)	Ensemble du réservoir,	Conjunto de tanque,
or	153-0094	1	Tank assembly (27 gal)	Ensemble du réservoir,	Conjunto de tanque,
or	153-0119	1	Tank assembly (30 gal)	Ensemble du réservoir,	Conjunto de tanque,
			<i>includes 18A-18F</i>	<i>inclut 18A-18F</i>	<i>incluye 18A-18F</i>
18A	033-0001	2	Hubcap	Chapeau de moyeu	Tapacubo
18B	095-0016	2	Wheel, 7" (11 gal)	Roue	Rueda
or	095-0010	2	Wheel, 8" (15, 20 & 21 gal)	Roue	Rueda
or	095-0028	2	Wheel, 9" (27 & 30 gal)	Roue	Rueda
18C	094-0029	2	Pad (20, 21, 27 & 30 gal)	Tampon	Almohadilla
or	094-0030	2	Pad (11 & 15 gal)	Tampon	Almohadilla
18D	512-0035	1	Bushing, 1-1/2 NPS x 1/4 NPT	Bague	Buje
	513-0002	1	O-ring 1-1/2"	Joint torique	Anillo tórico
18E	072-0001	1	Petcock	Robinet de décompression	Llave de desagüe
18F	093-0031	1	Handle grip	Poignée	Empuñadura
19	098-2336	1	Label, warning	D'avertissement étiquette	Amonestadora escritura de la
20	031-0071	1	Check valve	Anti-retour clapet	Válvula de cheque
21	061-0160	1	Screw, plastite #4-20 x 2"	Vis	Tornillo

*N/A - These are standard parts available at your local hardware store.



*N/A - Ces pièces sont des pièces standard disponibles en quincaillerie.

*N/A - Estas son piezas estándares disponibles en su ferretería local.

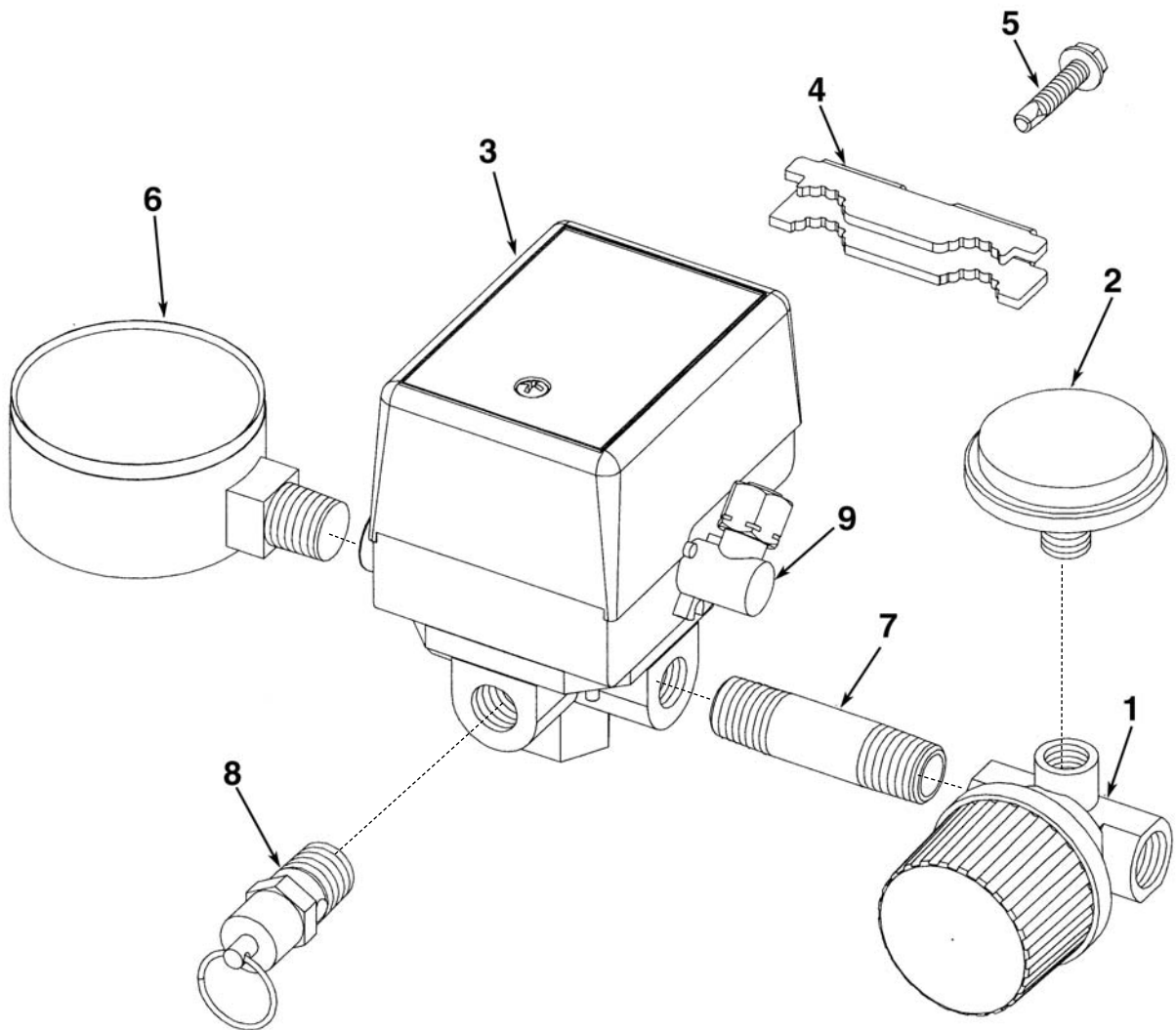
PARTS DRAWING / DESSIN DES PIÈCES / ESQUEMA DE LA PIEZAS



PARTS LIST / LISTE DE PIÈCES / LISTA DE LAS PIEZAS



Item Art <u>Art</u>	Part No N° / P <u>Núm / P</u>	Qty Qté <u>Cant</u>	 English <u>Description</u>	 French <u>Description</u>	 Spanish <u>Descripción</u>
1	019-0167	1	Regulator	Régulateur	Regulador
2	032-0056	1	Gauge, 1/8" NPT.....	Manomètre.....	Manómetro
3	034-0164	1	Pressure switch	Mano-contact	Interruptor de presión
4	071-0013	1	Strain relief.....	Soulagement de traction.....	Aliviador de esfuerzo
5	061-0121	1	Screw #10-32 x 15/16".....	Vis	Tornillo
6	032-0025	1	Gauge, 1/4" NPT.....	Manomètre.....	Manómetro
7	N/A	1	Nipple 1/4"NPT x 2"	Manchon fileté	Niple
8	136-0073	1	Relief valve	Soupape	Válvula
9	136-0064	1	Bleeder valve	Soupape	Válvula

PARTS DRAWING / DESSIN DES PIÈCES / ESQUEMA DE LA PIEZAS

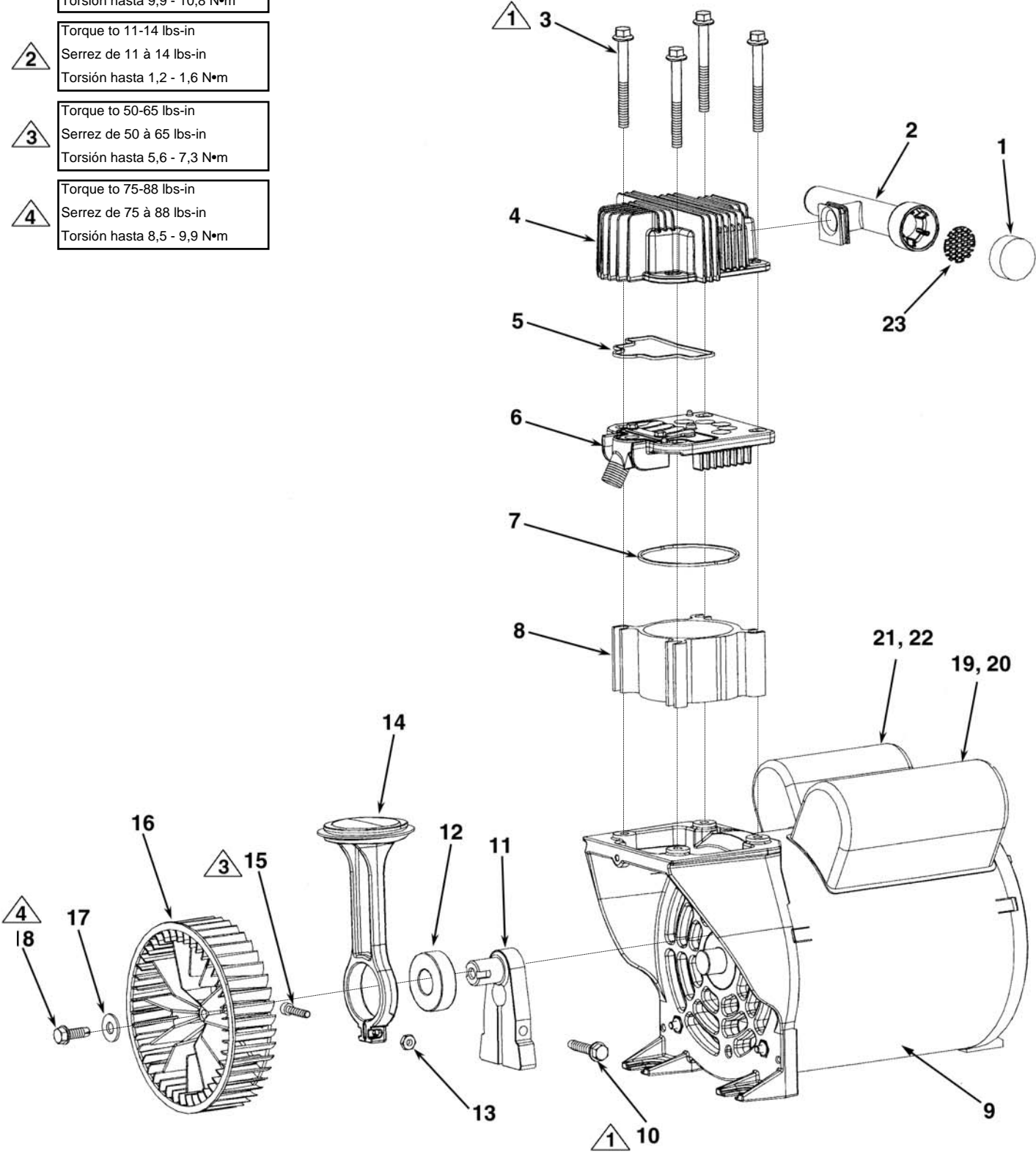
- 1** Torque to 88-96 lbs-in
Serrez de 88 à 96 lbs-in
Torsión hasta 9,9 - 10,8 N•m
- 2** Torque to 11-14 lbs-in
Serrez de 11 à 14 lbs-in
Torsión hasta 1,2 - 1,6 N•m
- 3** Torque to 50-65 lbs-in
Serrez de 50 à 65 lbs-in
Torsión hasta 5,6 - 7,3 N•m
- 4** Torque to 75-88 lbs-in
Serrez de 75 à 88 lbs-in
Torsión hasta 8,5 - 9,9 N•m



PARTS LIST / LISTE DE PIÈCES / LISTA DE LAS PIEZAS

Item Art Art	Part No N° / P Núm / P	Qty Qté Cant	 English	 French	 Spanish
			<u>Description</u>	<u>Description</u>	<u>Descripción</u>
1	019-0186	1	Filter.....	Filtre.....	Filtro
2	019-0192	1	Filter/intake muffler.....	Silencieux de Filter/intake....	Silenciador de Filter/intake
3	061-0186	4	Screw 1/4-20 x 2-3/4".....	Vis.....	Tornillo
4	042-0104	1	Head.....	Tête.....	Cabezal
5	054-0226	1	Head o-ring.....	Joint torique.....	Anillo tórico
6	043-0171	1	Valve plate assy..... (includes items 5 & 7).....	Ensemble de la plaque de ... Soupape (includ les éléments 5 et 7).....	Conjunto de placa de válvula (incluye los artículos 5 y 7)
7	054-0225	1	Cylinder o-ring.....	Joint torique.....	Anillo tórico
8	N/A	1	Cylinder..... (order 048-0105).....	Cylindre..... (commande 048-0105).....	Cilindro (orden 048-0105)
9	160-0296	1	Motor assy (2 peak hp).....	Ensemble du moteur.....	Conjunto de motor
or	160-0295	1	Motor assy (5&6 peak hp)..... Must be purchased as complete pump/motor assy.....	Ensemble du moteur..... vendu en une seule ensemble pompe/moteur.....	Conjunto de motor se debe comprar como un conjunto completo de bomba/motor
10	061-0135	1	Screw, 1/4-20 x 1-1/4" hex.....	Vis.....	Tornillo
11	053-0096	1	Crankshaft, eccentric..... (5 & 6 HP models)	Vilebrequin, excentrique.....	Cigüeñal, excéntrico
or	053-0086	1	Crankshaft, eccentric..... (LC631112 models)	Vilebrequin, excentrique.....	Cigüeñal, excéntrico
12	051-0086	1	Bearing, ball.....	Roulement.....	Cojinete
13	N/A	1	Nut, #10-32 square.....	Écrou.....	Tuerca
14	048-0105	1	Piston/cylinder kit..... (includes items 5,7,8,..... 13 & 15).....	Ensemble du piston..... et du cylindre..... (includ les éléments..... 5,7,8,13 et 15).....	Conjunto de cilindro y pistón (incluye los artículos 5,7,8,13 y 15)
15	N/A	1	Screw, #10-32 x 7/8".....	Vis.....	Tornillo
16	027-0033	1	Fan, plastic.....	En plastique ventilateur.....	Plástico ventilador
17	060-0144	1	Washer, 1/4".....	Rondelle.....	Arandela
18	061-0134	1	Screw, 1/4-20 x 3/4".....	Vis.....	Tornillo
19	166-0128	1	Start capacitor, 5&6 peak hp ..	Condensateur.....	Condensador
or	166-0117	1	Start capacitor, 2 peak hp.....	Condensateur.....	Condensador
20	166-0129	1	Start capacitor cover,..... 5 & 6 peak hp	Couvercle.....	Tapa
or	166-0054	1	Start capacitor cover,..... 2 peak hp	Couvercle.....	Tapa
21	166-0130	1	Run capacitor, 5 & 6 peak hp ..	Condensateur.....	Condensador
22	166-0131	1	Run capacitor cover..... 5 & 6 peak hp	Couvercle.....	Tapa

*N/A - These are standard parts available at your local hardware store.

*N/A - Ces pièces sont des pièces standard disponibles en quincaillerie.

*N/A - Estas son piezas estándares disponibles en su ferretería local.



PARTS AND SERVICE

Replacement parts and service are available from your nearest authorized Service Center. If the need arises, contact Product Service as listed at right.

When consulting with a Service Center or Product Service, refer to the model number and serial number located on the serial label of the compressor. Proof of purchase is required for all transactions and a copy of your sales receipt may be requested.

Record the model number, serial number, and date purchased in the spaces provided below. Retain your sales receipt and this manual for future reference.

Model No.

Serial No.

Date Purchased, la date d'achat, la fecha de compra

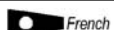

PIÈCES ET RÉPARATIONS

Pour pièces de rechange et réparations de votre Centre d'Entretien autorisé le plus proche. Au besoin, veuillez contacter le service après-vente (Product Service) au numéro de téléphone ou à droite.

Lorsque vous appelez un Centre d'Entretien ou le service après-vente, veuillez indiquer le numéro de modèle et le numéro de série situé sur la étiquette de série du compresseur. Une preuve d'achat est nécessaire lors de toute transaction et une copie de votre reçu peut être exigée.

Inscrivez la date d'achat au-dessus de, dans les

When needing service, please contact the nearest authorized Service Center or call:

PRODUCT SERVICE



In U.S.A. or Canada

Toll-Free

Fax

1-888-895-4549

1-507-723-5013

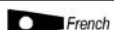

REPUESTOS Y SERVICIO

Las piezas de repuesto y el servicio están disponibles del Centro de Servicio autorizado más cercano. Consulte con el Servicio al Cliente (Product Service) listado debajo, si surge la necesidad.

Refiérase al número de modelo y el número de serie situado en la etiqueta de serie del compresor, cuando consulte con un Centro de Servicio o el Servicio al Cliente. Se requiere la prueba de compra para todas las transacciones y puede requerirse una copia de su recibo de venta.

espaces réservé à cet effet. Conservez votre reçu et ce manuel pour référence ultérieure.

Quand vous avez besoin des services de l'usine, s'il vous plaît contactez au centre d'entretien autorisé le plus proche ou composez simplement le :

SERVICE CLIENTÈ



Au Canada

Appel gratuit

Télécopieur

1-888-895-4549

1-507-723-5013

En los espacios provisto arriba registre la fecha de compra. Guarde su recibo de venta y este manual para referencia futura.

Cuando necesite servicio por favor de consultar el centro de servicio autorizado más cercano o notificar por correo a:

Product Service

Sanborn Mfg., Division of MAT Industries, LLC.

118 West Rock Street

Springfield, MN 56087

Made in USA with domestic and foreign components
Fabriqué aux États – Unis à l'aide de composants de l'intérieur et de l'étranger
Hecho en EE.UU. con componentes domésticos y extranjeros

© 2008 **Sanborn Mfg.**
Division of MAT Industries, LLC.
Springfield, MN 56087

1-888-895-4549

All Rights Reserved. Tous droits réservés. Reservados todos los derechos.