



-  **Oilless, Single-Stage, Direct-Drive, Electric Air Compressors**
-  **Sans l'huile, d'une seul étape, à prise directe, compresseurs d'air électriques**
-  **Sin aceite, de una sola etapa, de mando directo, compresores de aire eléctricos**



MODEL NO. (MODÈLE) (MODELO)	H.P. (CV)	TANK CAPACITY GALLONS (CAPACITÉ DU RÉSERVOIR - LITRES) (CAPACIDAD DEL TANQUE - LITROS)	VOLTAGE/ AMPS/ PHASE (TENSION/ AMPS/ PHASE) (VOLTAJE/ AMP/ FASE)	CFM	CFM	MAXIMUM PRESSURE (PRESSION DE MAXIMUM) (PRESION DE MÁXIMO)
				(l/min) @ 40 PSI (2,8 bar)	(l/min) @ 90 PSI (6,3 bar)	
25C025P1D1	2.5	2.5 (9,5)	115/15/1	7.3 (207)	4.2 (119)	120 (8,4 bar)

Note: Air Tool CFM Ratings Vary. It is recommended to test each air tool with an air compressor to determine if the air tool operates adequately with the air compressor.

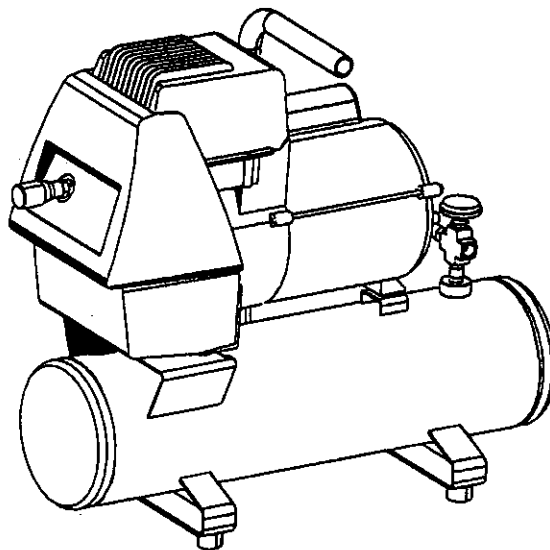

Questions? See back page. _____ Questions ? Consultez la page final. _____ ¿Preguntas? Vea la página final.

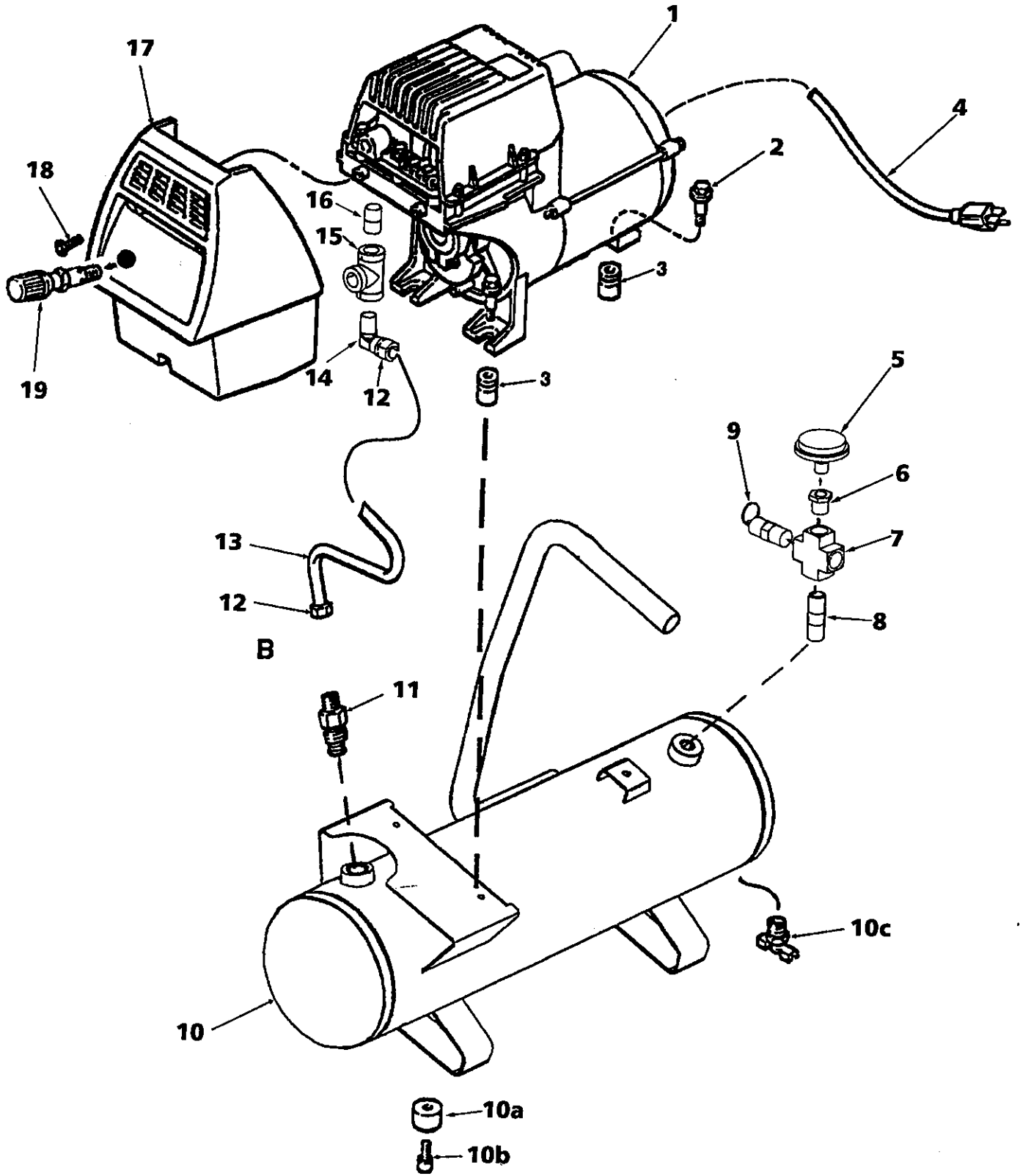

PARTS LIST

LISTE DE PIÈCES

LISTA DE LAS PIEZAS

Item Art Art	Part No N° / P Núm / P	Qty Qté Cant	Description	Description	Descripción
1	040-0291	1	Pump/motor assy	ensemble pompe/moteur	Conjunto de bomba/motor
2	059-0221	3	Bolt, should, 1/4-28	Boulon	Perno
3	093-0019	3	Grommet	Oeillet	Arandela de cabo
4	026-0289	1	Cord, power	Câble	Cordón
5	032-0052	1	Gauge, 200 PSI	Manomètre	Manómetro
6	063-0023	1	Bushing, 1/4 NPT x 1/8 NPT	Bague	Buje
7	028-0005	1	Cross, 1/4" brass		
8	065-0033	1	Nipple, 1/4 NPT x 1.50" lg	Manchon fileté	Niple
9	136-0037	1	Valve, 135 PSI, 1/4 NPT ASME	Soupape	Válvula
10	150-0061	1	Tank assy, includes 10a-10c	Ensemble du réservoir	Conjunto de tanque
			2.5 gallon	9.5 litres	9.5 litros
10a	094-0026	4	Isolator, vibration	Tampon	Almohadilla
10b	061-0060	4	Screw	Vis	Tornillo
10c	072-0001	1	Petcock	Robinet de décompression	Llave de desagüe
11	031-0047	1	Valve, check	Soupape	Válvula
			1/2 NPT x 3/8" O.D. tube		
12	058-0007	2	Nut, 3/8" O.D. tube	Écrou	Tuerca
13	145-0306	1	Tube transfer	Tube	Tubo
			Also purchas 058-0007 qty 2	también être acheté	aussi debe comprar
14	064-0001	1	Elbow 90° 1/4" x 3/8" tube	Coude	Codo
15	069-0004	1	Tee 1/4" iron	Pieceent	T
16	065-0031	1	Nipple - 1/4" close	Manchon fileté	Niple
17	142-0108	1	Shroud	Enveloppe	Guarder
18	061-0108	3	Screw, #8-32 x 7/16" lg	Vis	Tornillo
19	020-0015	1	Valve, pressure control	Soupape	Válvula

Pump specifications

Weight - 34 lbs. approx.
Max RPM - 3500

Spécifications de la pompe

Poids - 15,4 Kg
Régime maximum - 3500 Tr/Min

Especificaciones de la bomba

Peso - 15,4 Kg
RPM max - 3500

040-0291 PUMP/MOTOR ASSEMBLY
(Ensemble pompe/moteur)
(Conjunto de bomba/motor)

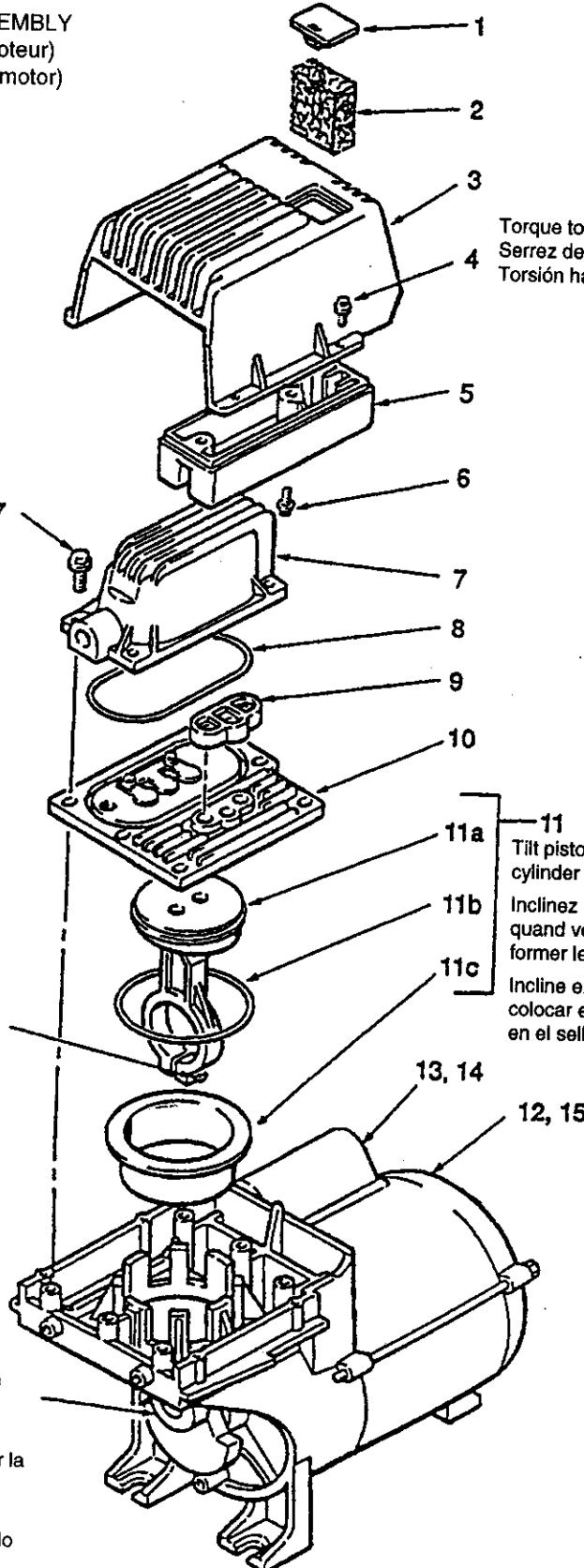

Torque to 15-20 in-lbs.
Serrez de 15 à 20 in-lbs
Torsión hasta 1,7 - 2,3 N•m

Torque to 120-150 in-lbs.
Serrez de 120 à 150 in-lbs
Torsión hasta 13,6 - 16,9 N•m

Torque to 40-50 in-lbs.
Serrez de 40 à 50 in-lbs
Torsión hasta 3,4 - 4,5 N•m

11
Tilt piston assy (11a) slightly when placing into cylinder (11c) to form lips on seal.

11a
11b
11c
Inclinez légèrement l'assemblage du piston quand vous le placez dans le cylindre pour former les lèvres sur le joint.

Incline el conjunto del piston (11a) levemente al colocar en el cilindro #11c) para formar los labios en el sello.

Place piston assy over bearing and align before tightening screw on piston assy to noted torque.

Placez l'assemblage du piston sur la roulement (3) et alignez avant de serrer la vis du piston au couple rcommandé.

Coloque el conjunto del piston sobre el cojinete y allnee antes de ajustar el tornillo del conjunto del piston hasta la torsion indicada.

200-2197

040-0291

Item Art Art	Part No Nº / P Núm / P	Qty Qté Cant	Description	Description	Descripción
1	077-0118	1	Cover	Couvercle.....	Tapa
2	019-0152	1	Filter	Filtre	Filtro
3	077-0136	1	Cover	Couvercle.....	Tapa
4	061-0061	4	Screw, #8-32 x .38" lg	Vis	Tornillo
5	019-0151	1	Manifold	Collecteur.....	Múltiple
6	061-0060	2	Screw, #8-32 x .75" lg	Vis	Tornillo
7	117-0011	1	Manifold	Collecteur.....	Múltiple
8	054-0157	1	O-ring	Joint torique	Anillo tórico
9	046-0231	1	Seal	Joint	Sello
10	043-0151	1	Valve plate assembly	Ensemble de la plaque de soupape	Conjunto de placa de válvula
11	048-0074	1	Piston & cylinder assy	Ensemble du piston	Conjunto de
			<i>includes items 11a-11c</i>	<i>et du cylindre</i>	<i>cilindro y pistón</i>
				<i>inclut les éléments 11a-11c</i>	<i>incluye los artículos 11a-11c</i>
11a	NA	1	Piston assy.....	Ensemble du piston	Conjunto de pistón
11b	054-0158	1	O-ring	Joint torique	Anillo tórico
11c	NA	1	Cylinder.....	Cylindre.....	Cilindro
12	NA	1	Motor assy	Ensemble du moteur.....	Conjunto de motor
			must be purchased as	vendu en une seule	se debe comprar como
			complete pump/motor assy	ensemble pompe/moteur	un conjunto completo de bomba/motor
13	166-0040	1	Capacitor, start, black	Condensateur	Condensador
14	166-0054	1	Cover	Couvercle.....	Tapa
15	077-0137	1	Cover, terminal.....	Couvercle.....	Tapa
17	061-0062	6	Screw, 1/4-20 x 1.12"lg	Vis.....	Tornillo

Service kits available

Jeux de pièces d'entretien disponibles

Juegos de servicio disponibles

046-0234	Seal kit.....	Jeu de joints.....	Juego de sellos
	includes items	inclut les éléments	incluye los artículos
	8, 9 & 11b	8, 9 & 11b	8, 9 & 11b