

MODEL 040-0210

PARTS DRAWING _____ DESSIN DES PIÈCES _____ ESQUEMA DE LAS PIEZAS

PUMP B5900

PUMP SPECIFICATIONS
 WEIGHT - 48 LBS.
 OIL GRADE - 10W30
 CAPACITY - 70 OZS.
 MAX. RPM - 1450

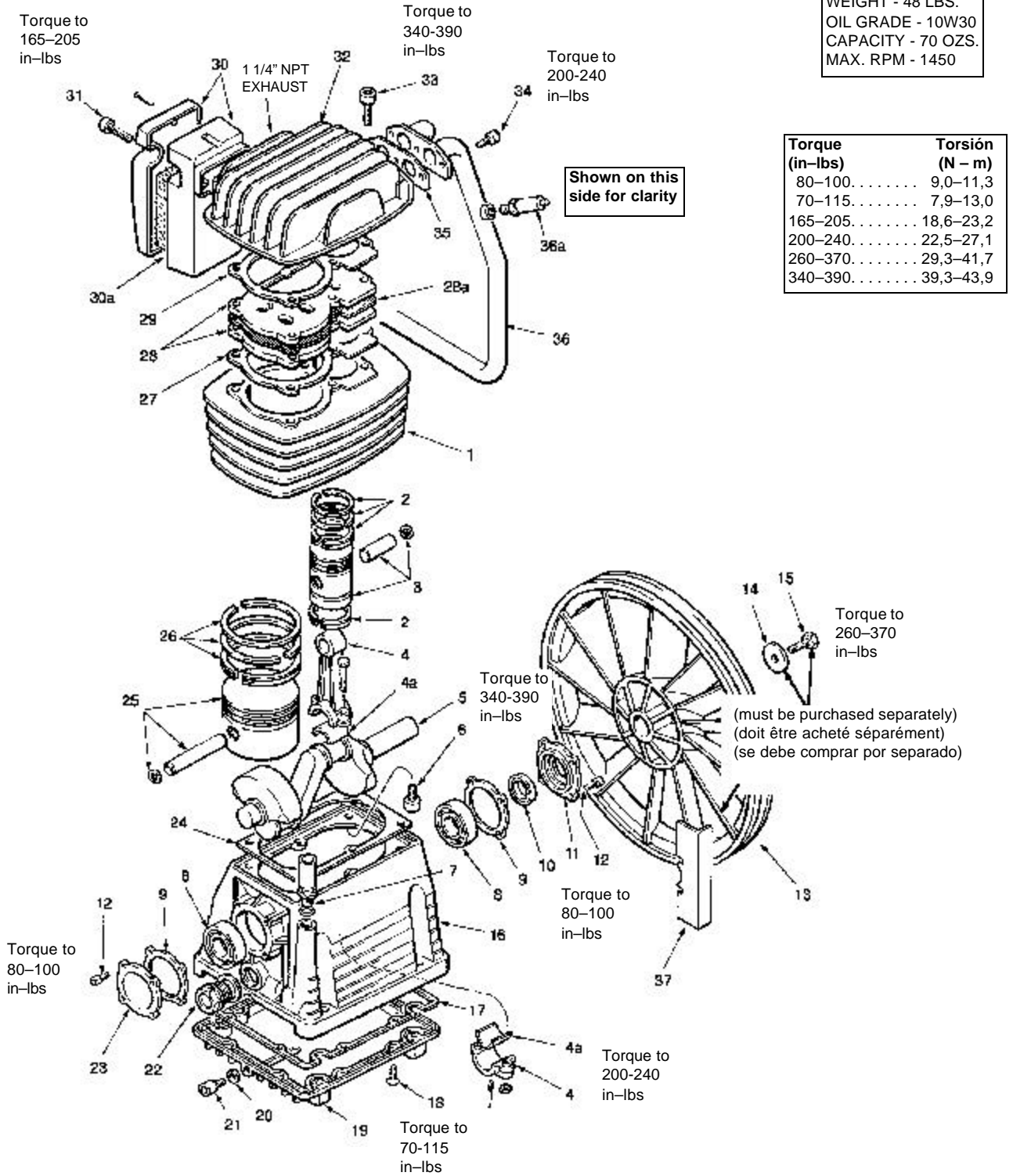

Torque (in-lbs)	Torsión (N - m)
80-100.....	9,0-11,3
70-115.....	7,9-13,0
165-205.....	18,6-23,2
200-240.....	22,5-27,1
260-370.....	29,3-41,7
340-390.....	39,3-43,9

MODEL 040-0210

PARTS LIST _____ LISTE DE PIÈCES _____ LISTA DE LAS PIEZAS

PUMP B5900

Item Art Art	Part No Nº / P Núm / P	Qty Qté Cant	Description	Description	Descripción
1	050-0040	1	Cylinder.....	Cylindre.....	Cilindro
2	054-0129	1	Ring set.....	Jeu d'anneaux.....	Juego de reparación
3	048-0043	1	Piston assy.....	Ensemble du piston.....	Conjunto de pistón
4	047-0039	2	Rod..... includes item 4a, bolt, nut and splash rod	Tige..... inclut les élément 4a, boulon, écrou et tige de dispersion	Varilla..... incluye los artículo 4a, perno, Tuerca y varilla de salpicadura
4a	051-0041	2 pr	Inserts.....	Pièce rapportée.....	Inserto
5	053-0064	1	Crankshaft.....	Vilebrequin.....	Cigüeñal
6	059-0134	6	Bolt.....	Boulon.....	Perno
7	056-0029	1	Breather, includes item 7a.....	Reniflard.....	Respiradero
7a	046-0254	1	O-ring.....	Joint torique.....	Anillo tórico
8	051-0039	2	Bearing.....	Roulement.....	Cojinete
9	046-0135	2	Gasket.....	Joint.....	Empaquetadura
10	046-0137	1	Seal.....	Joint.....	Sello
11	077-0055	1	Cover.....	Couvercle.....	Tapa
12	059-0135	8	Bolt.....	Boulon.....	Perno
13	044-0059	1	Flywheel.....	Volant-moteur.....	Volante
14**	060-0052	1	Washer.....	Rondelle.....	Arandela
15**	059-0138	1	Bolt.....	Boulon.....	Perno
16**	049-0038	1	Crankcase.....	Carter.....	Cárter
17	046-0246	1	Gasket.....	Joint.....	Empaquetadura
18	059-0229	8	Bolt.....	Boulon.....	Perno
19	077-0125	1	Base.....	Base.....	Base
20	060-0051	1	Washer.....	Rondelle.....	Arandela
21	059-0137	1	Bolt.....	Boulon.....	Perno
22	032-0019	1	Sight glass, includes item 22a.....	Viseur.....	Mirilla de vidrio
22a	046-0255	1	Washer.....	Rondelle.....	Arandela
23	077-0053	1	Cover.....	Couvercle.....	Tapa
24	046-0247	1	Gasket.....	Joint.....	Empaquetadura
25	048-0086	1	Piston assy.....	Ensemble du piston.....	Conjunto de pistón
26	054-0217	1	Ring set.....	Jeu d'anneaux.....	Juego de reparación
27	046-0257	1	Gasket.....	Joint.....	Empaquetadura
28	043-0161	1	Valve plate assy..... includes item 28a	Ensemble de la plaque de..... soupape	Conjuncto de placa de válvula
28a	046-0256	1	Gasket.....	Joint.....	Empaquetadura
29	046-0258	1	Gasket.....	Joint.....	Empaquetadura
30	019-0104	1	Air filter assy, includes item 30a.....	Ensemble de filtre à air.....	Conjunto de filtro de aire
30a	019-0105	1	Element.....	Élément.....	Elemento
31	059-0230	2	Bolt.....	Boulon.....	Perno
32	042-0086	1	Head.....	Tête.....	Cabezal
33	059-0231	6	Bolt.....	Boulon.....	Perno
34	059-0232	3	Bolt.....	Boulon.....	Perno
35	046-0245	1	Gasket.....	Joint.....	Empaquetadura
36	082-0024	1	Tube, includes item 36a.....	Tube, inclut les élément 36a.....	Tube, incluye los artículo 36a
36a	136-0049	1	Valve, pressure relief.....	Soupape.....	Válvula
37	125-0105	1	Shield.....	Garant.....	Pantalla

AVAILABLE SERVICE KITS
must be purchased separately
separado

doit être acheté séparément

se debe comprar por

046-0244	Gasket repair kit.....	Joint de jeu de pièces de..... réparation	Empaquetadura de juego de reparación
	includes items 9, 17, 24, 27, 28a, 29, 35, 40 & 42	inclut les élément 9, 17, 24, 27, 28a, 29, 35, 40 et 42	incluye los artículo 9, 17, 24, 27, 28a, 29, 35, 40 y 42

** Items must be purchased separately when ordering the pump assembly, if needed.

**Des elements doivent etre achetes seperately en commandant le pompe si necessaire.

**Los items deben comprados seperately al pedir el ensamblaje de la bomba si estan necesitados.

DATE 7/21/00

ORIGINAL