

SERVICE PARTS LIST

**MODEL
INDUSTRIAL 10 & 12KW**

**PART NUMBER
PM0610023
PM0612023
PC0610023
PC0612023**

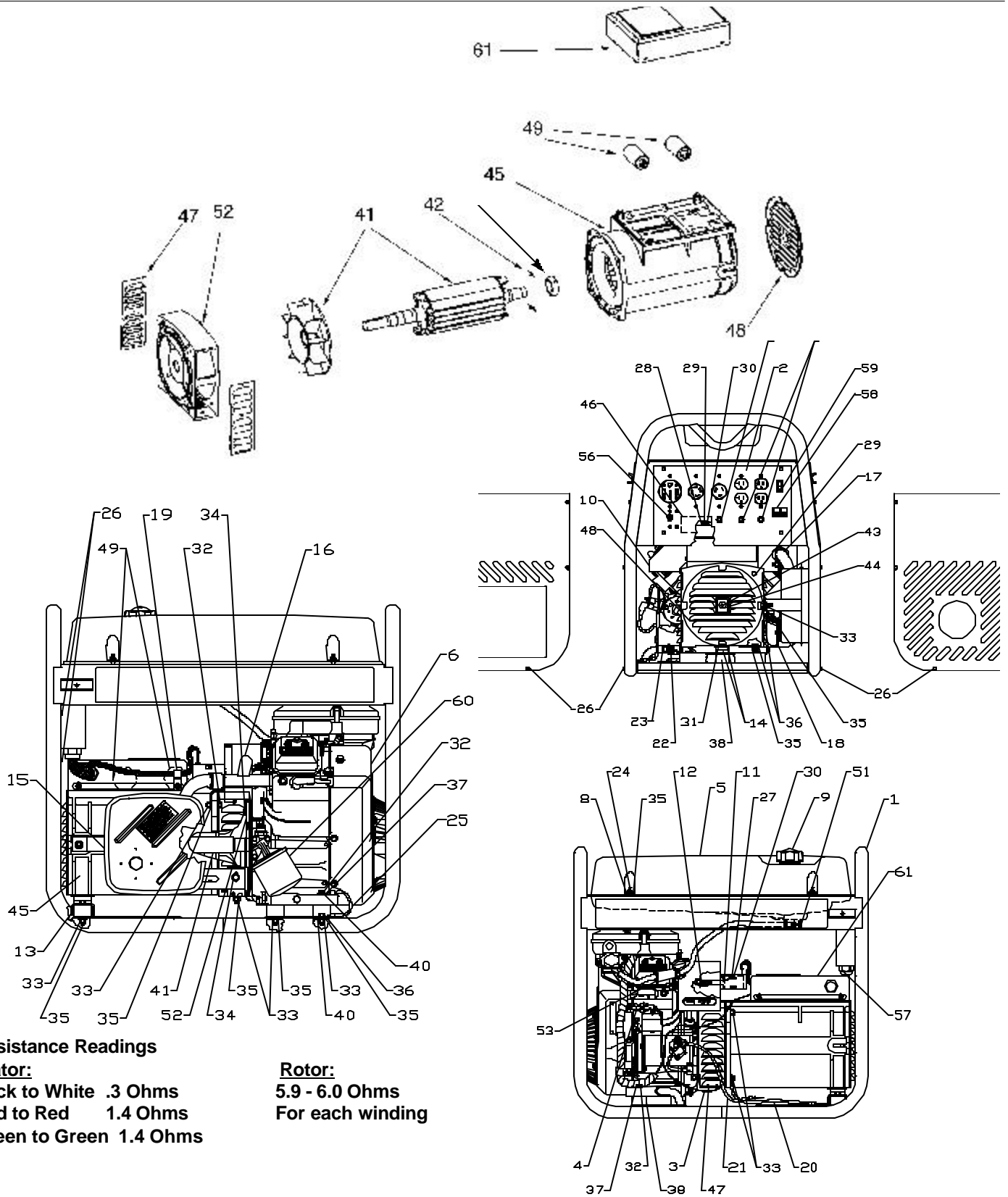

Resistance Readings

Stator:

Back to White .3 Ohms
 Red to Red 1.4 Ohms
 Green to Green 1.4 Ohms

Rotor:

5.9 - 6.0 Ohms
 For each winding

PARTS LIST / LISTE DES PIÈCES / LISTA DE PIEZAS

REF. NO.	PART NO.	DESCRIPTION	DESCRIPTION	DESCRIPCION				
					PM0610023	PM0612023	PC0612023	PC0610023
1	0056241	Carrier, assembly, full	Ensemble transport	Transportador, conjunto	1			1
1	0056669	Carrier, assembly, full	Ensemble transport	Transportador, conjunto		1	1	
2	0056242	Panel, wired complete	Tableau compl. câblé	Panel, abeado completo	1			
2	0056704	Panel, wired complete	Tableau compl. câblé	Panel, abeado complet		1		
2	0056725	Panel, wired complete	Tableau compl. câblé	Panel, abeado complet			1	
2	0056724	Panel, wired complete	Tableau compl. câblé	Panel, abeado complet				1
3	0006897	Assy, Wire 18 ga. 29"	Assemblage, Câble	Conjunto Cable	1	1	1	1
4	Note B	TermTab Adapter	Adaptateur	Adaptador	1	1	1	1
5	0056234	Fuel tank Assmely	Assemb. complet du réservoir	Conjunto tanque	1	1	1	1
6	Note A	Engine, 18hp	Moteur	Motor	1			1
6	Note A	Engine, 23hp	Moteur	Motor		1	1	
8	0048243	Bushing, step	Bagues de reeduction à gradins	Casquillo, paso	4	4	4	4
9	0056231	Cap Fuel w/Gauge 6"	Capuchon, réservoir d'essence	Tapa combustible	1	1	1	1
10	0056410	Assy, deflector	Assemblage, déflecteur	Assemb. déflecteur	1	1	1	1
11	0050426	Solenoid, IC	Solénoïde	Solenoid	1	1	1	1
12	0056436	Spring, Solenoid	Ressort, Solénoïde	Resorte, Solenoide	1	1	1	1
13	0056427	Assy, Stator bracket	Patte de fixation stator	Soporte, estator	1	1	1	1
14	0055620.01	Washer, flat .42 x 1.5 x .313	Rondelles plates	Tornillo	2	2	2	2
15	0056434	Muffler	Silencieux	Silenciador	1			1
15	0056673	Muffler	Silencieux	Silenciador		1	1	
16	0056435	Manifold, Exhaust	Silencieux joint	Descarga colector de escape.	1			1
16	0056674	Manifold, Exhaust	Silencieux joint	Descarga colector de escape		1	1	
17	0056447	Muffler Clamp	Silencieux joint	Grapa de silenciador	1			1
17	0055952	Muffler Clamp	silencieux joint	Grapa de silenciador		1	1	
18	0050941.01	Muffler Bracket	Silencieux fixation	Soporte de silenciador.	1	1	1	1
19	0052931	Clamp, Vinyl J 1/2"	Collier	Abrazadera	1	1	1	1
20	0006253	Assy, Wire Blk 8 ga. 17.25"	Fil	Alambre	1	1	1	1
21	0006254	Assy, Wire Red 8 ga. 17.25"	Fil	Alambre	1	1	1	1
22	0056448	Oil Drain	Vidange	Aceite lubricante vaciar.	1			1
23	0057076	Oil Drain Hose	Boyau de vidange d'huile	Manguera para drenar el aceite.	1	1	1	1
24	Note B	Nut, nyloc 1/4-20	Écrous nyloc	Tuerca, nyloc	4	4	4	4
25	0049224	Assembly, ground wire	Ens. fil de masse tressé	Conjunto, cable trenzado a tierra	1	1	1	1
26	0053320	Screw, HWH 1014x .63	Vis	Tornillo	4	16	16	4
27	0001537	Screw, HSW 8-32x .38	Vis	Tornillo	4	4	4	4
28	Note B	Washer, Flat 1/4	Rondelles plates	Arandela, plana	1	1	1	1
29	0047864	Screw, HSW 10-32x .5	Vis	Tornillo	2	2	2	2
30	Note B	Washer, star #10	Rondelles à dents	Arandela, estrella externa	5	5	5	5
31	Note B	Bolt, HH 5/16-18x 1.25	Boulon	Perno	1	1	1	1
32	Note B	Bolt, HH 5/16-18x 1.5	Boulon	Perno	8	8	8	8
33	Note B	Nut Nyloc 5/16-18	Écrous nyloc	Tuerca, nyloc	14	14	14	14
34	Note B	Bolt, wz 3/8-16 X 3/4	Boulon, wz	Perno, wz	5	5	5	5
35	Note B	Washer, flat 5/16	Rondelles plates	Tornillo	6	16	16	6
36	Note B	Bolt, HH 5/16-18	Boulon	Perno	3	3	3	3
37	Note B	Washer, lock 5/16	Contre-écrou	Arandela, de cierre	4	4	4	4
38	0051094	Isolator	Sectionneur	Aislador	5	5	5	5
40	Note B	Washer, star ext.5/16	Rondelles à dents	Arandela, estrella externa	2	2	2	2
41	0056624	Rotor, 10 kw	Rotor, 10kw	Rotor, 10 kw	1	1	1	1
42	0056625	Rotor, diodes	Rotor, diodes	Roter, diodes	2	2	2	2
43	0056626	Bearing	Palier	Balero	1	1	2	2
44	0056627	Bolt, 330mm	Boulon	Perno	1	1	1	1
45	0056628	Stator, 10Kw, 60 Hz	Stator	Estator	1	1	1	1
46	0056552	I/C Module DC.	Module de commande du ralenti	Módulo, control en vacío	1			1
46	0056539.01	I/C Module DC.	Module de commande du ralenti	Módulo, control en vacío		1	1	
47	0056629	Louvered Side Panel	Panneau latéral à persiennes	Tablero lateral con rejillas.	2	2	2	2
48	0056630	Endpanel, Louvered	Panneau d'extrémité à persiennes	Tablero final con rejillas.	1	1	1	1
49	0056631	Capacitor, 35 mfd 450V	Capaciteur	Capacitor	2	2	2	2
51	0049114	Fuel valve with bushing	Robinet de carburant avec bague	Válvula combustible con casquillo	1	1	1	1
52	0056623	Adapter, engine	Adaptateur pour moteur	Adaptador, motor	1	1	1	1
53	Note A	Fuel filter	Filtre à carburant	Filtro combustible	1	1	1	1
54	0049071	Circuit Breaker 20A	Disjoncteurs	Cortacircuitos	2	2	2	2
55	0048337	Circuit Breaker 35A	Disjoncteurs	Cortacircuitos	1	1	1	1
56	0056441	Circuit Breaker 40a dual	Disjoncteurs	Cortacircuitos	1			1
56	0056705	Circuit Breaker 50a dual	Disjoncteurs	Cortacircuitos		1	1	
57	0049291	Strain Relief	Réducteur de tension	Protección contra tirones	1	1	1	1
58	0056438	Hour Meter	Compteur d'heures	Contador de horas.	1	1	1	1
59	0050298	Rocker Switch	Interrupteur à bascule	Interruptor de balancín.	1	1	1	1
60	Note A	Oil Filter	Huile filtrer	Aceite lubricante filtro.	1	1	1	1
61	0056632	Generator Head cover	Couvercle de la tête de la gereratrice	Cubierta del cabezal del generador	1	1	1	1
62	0056667	Panel Muffler Side	Panneau	Tablero		1	1	
63	0056666	Panel Battery Side	Panneau	Tablero		1	1	
*	0052296	Battery Hold Down Kit	Batterie barre de retenue assemblage	Barra sujetadora.	1	1	1	1
*	0056443	Portability Kit Complete	Trousse de transport complète	Equipo portátil completo.	1	1	1	1
*	0056680	Filler Footool Funnel	Entonnoir	Embudo	1	1	1	1