

SCHEMATIC FOR PMP12K18

OPTIONAL AFTERCOOLER

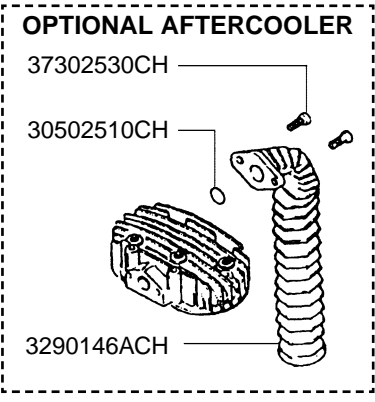

37302530CH
30502510CH
3290146ACH

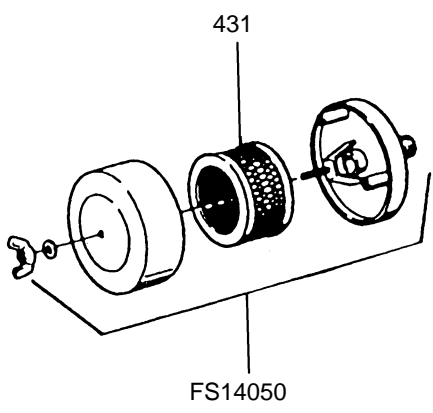

431
FS14050

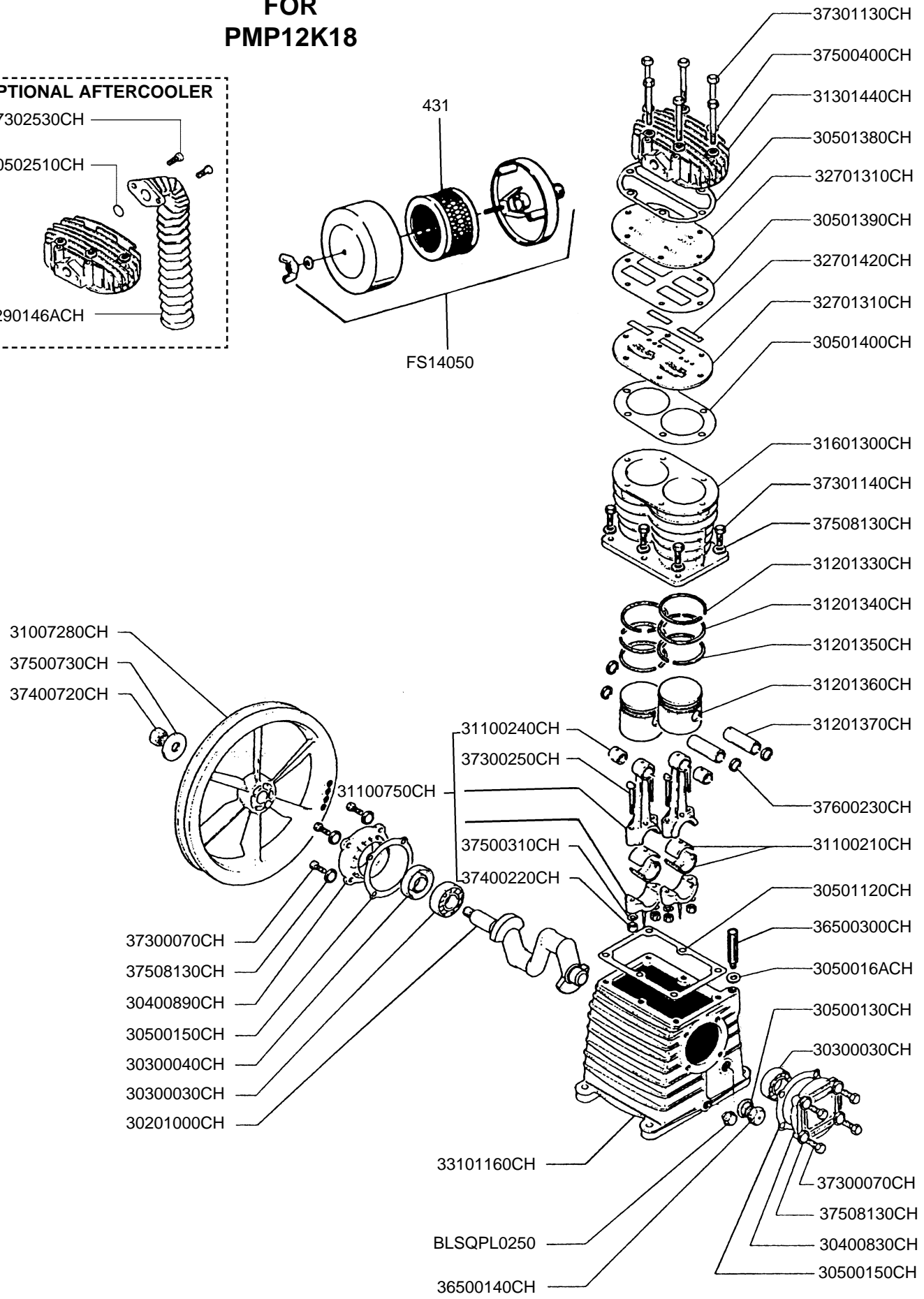

31007280CH
37500730CH
37400720CH
31100750CH
37300070CH
37508130CH
30400890CH
30500150CH
30300040CH
30300030CH
30201000CH
31100240CH
37300250CH
37500310CH
37400220CH
33101160CH
BLSQPL0250
36500140CH
37301130CH
37500400CH
31301440CH
30501380CH
32701310CH
30501390CH
32701420CH
32701310CH
30501400CH
31601300CH
37301140CH
37508130CH
31201330CH
31201340CH
31201350CH
31201360CH
31201370CH
37600230CH
31100210CH
30501120CH
36500300CH
3050016ACH
30500130CH
30300030CH
37300070CH
37508130CH
30400830CH
30500150CH



Associate Engineering Corporation

606 S. Lake Street P.O. Box 346

Hustisford, Wisconsin 53034-0346

Phone: 920-349-3281

Sales Fax: 920.349.3691 Service Fax: 920.349.8861

www.rolair.net

PARTS LIST FOR PMP12K18

Description	Part #	Qty.
Crankshaft	30201000CH	1
Ball Bearing	30300030CH	2
Oil Seal	30300040CH	1
Bearing Carrier	30400830CH	1
Bearing Carrier	30400890CH	1
Gasket	30500130CH	1
Gasket	30500150CH	2
3/8" Hole Gasket	3050016ACH	1
Gasket	30501120CH	1
Gasket	30501380CH	1
Gasket	30501390CH	1
Gasket	30501400CH	1
Flywheel	31007280CH	1
Bearing Shell	31100210CH	2
Bushing*	31100240CH	2
Connecting Rod w/ upper bushing	31100750CH	2
Compression Ring	31201330CH	2
Stepped Scraper Ring	31201340CH	2
Slotted Oil Ring	31201350CH	2
Piston	31201360CH	2
Piston Pin	31201370CH	2
Cylinder Head	31301440CH	1
Cylinder	31601300CH	1
Valve Plate	32701310CH	2
Valve	32701420CH	4
Crankcase	33101160CH	1
Oil Sight Gauge	36500140CH	1
3/8" Breather/Oil Fill Plug	36500300CH	1
Bolt	37300070CH	8
Bolt	37300250CH	4
Bolt	37301130CH	6
Bolt	37301140CH	6
Nut	37400220CH	4
Nut	37400720CH	1
Washer	37500310CH	4
Washer	37500400CH	6
Washer	37500730CH	1
Washer	37508130CH	14
Snap Ring	37600230CH	4
Filter Element	431	1
1/4" Square Head Plug	BLSQPL0250	1
Filter Assembly	FS14050	1
Ring Set	K18RINGS	1
Gasket Set	K18GASKETS	1
Valve Plate Assembly	1800VK18	1
OPTIONS — "O" Ring	30502510CH	1
Aftercooler	3290146ACH	1
Bolt	37302530CH	2
NOTE: Gasket for "old-style" aftercooler	30501490CH	1

*Bushing is not machined to fit piston pin if ordered separate from connecting rod.