



M157304G

ITEM NUMBER: 157304
 SERIAL NUMBER: _____
 HP: _____ Volts: _____ Amp: _____ Ph: _____
 RPM: _____ PSI: _____ GPM: _____ Nozzle Size: _____
 Pump: _____ Hose: _____ Lance: _____
 Max. Discharge Temperature: _____

Installation, Operation, and Maintenance Manual

Cold Water Pressure Washer: *Cleans dirty surfaces with high-pressure water.*

To the Owner:

Thank you for purchasing a NorthStar pressure washer. Your machine is designed for long life, dependability, and the top performance you demand! Take time now to read through this manual so you better understand the machine's operation, maintenance and safety precautions. Everyone who operates this machine must read and understand this manual. The time you take now will prolong your machine's life and prepare you for its safe operation. Enjoy the exceptional performance of your NorthStar pressure washer, the industry leader! The manufacturer reserves the right to make improvements in design and/or changes in specifications at any time without incurring any obligation to install them on units previously sold.

Quick Facts

Pump Oil	Pump is shipped with oil. Change oil plug and check pump oil level before starting. Use SAE 30 Non-detergent pump oil (item# 4043) or Cat Pump oil (item# 22158) for oil changes.	
Water	Make sure your water flow is 20% higher than the pressure washer's flow rate. Make sure your water is clean and particle free. Maximum inlet water temp. 140°F (60°C)	
Storage	Do not allow water to freeze in the pump, hose, or spray gun.	
Spraying Chemicals	Use any North Star brand or equivalent pressure washer chemicals. Adjust soap adjustment knob to regulate cleaning power.	
Maintenance Schedule	Pump:	Oil: change after first 50 hours, then every 3 months or 500 hours.

Read and understand all manuals before operating.

Any Questions, Comments, Problems or Parts Orders
Call NorthStar Product Support 1-800-270-0810

Table of Contents			
Important Safety Instructions	2	Maintenance Instructions	10-11
Grounding Instructions	2	Long Term Storage	11
Machine Component Identification	3	Troubleshooting	12
Installation Instructions	4-7	Parts Breakdowns	13-15
Operating Instructions	8-10	Wiring Diagram	16
		Limited Warranty	17

Important Safety Instructions

WARNING -Risk of Injection or Injury to Persons - Do Not Direct Discharge Stream at Persons. - Do not use a hose if exterior damage is evident.

-Risk of explosion. - Do not spray flammable liquids. - Do not operate in a flammable environment.

CAUTION -Gun kicks back. Hold with both hands.

-To reduce the risk of injury, read operating instructions carefully before use.

WARNING - When using this product basic precautions should always be followed, including the following:

- 1.) Read all the instructions before using the product.
- 2.) To reduce the risk of injury, close supervision is necessary when the product is used near children. Do not allow irresponsible use by children. Always stop the product and bleed pressures before leaving unattended, disconnecting hoses, or servicing the pump.
- 3.) Know how to stop the product and bleed pressures quickly. Be thoroughly familiar with the controls.
- 4.) Stay alert - watch what you are doing.
- 5.) Do not operate the product when fatigued or under the influence of alcohol or drugs. Never smoke while operating this machine.
- 6.) Keep operating area clear of all persons.
- 7.) Do not overreach or stand on unstable support. Keep good footing and balance at all times. Wear footwear capable of maintaining a good grip on wet surfaces - Do not place the machine on soft or unstable ground.
- 8.) Follow the maintenance instructions specified in all manuals. Do not run machine without sufficient lubrication or sufficient water to cool the pump.
- 9.) Wear safety glasses, gloves, face protection and appropriate clothing when operating the machine.
- 10.) Do not operate this machine with broken or missing parts. - Never alter the manufacturer's original design or deactivate any safety device on the machine.
- 11.) Risk of exposure to dangerous chemicals. Wear protective gloves when handling and cleaning with chemicals. Follow the chemical manufacturer's directions. Understand all safety hazards and first aid for all chemicals being used. Check whether dangerous chemicals have been used and take any precautions that may have been recommended by the supplier of these chemicals when cleaning filters. Do not pump highly abrasive fluids or use with incompatible chemicals or solvents.
- 12.) Know the pressure and temperature limits of your machine. Be sure all high pressure accessories meet or exceed your machine's limits. Do not set the pressure relief valve above the machine's limit.
- 13.) Do not move this machine by pulling on the hose. Do not use the pump to support other items of equipment that impose unacceptable loads on the pump. Do not attempt to use this machine as a prop.
- 14.) To reduce risk of injury, do not secure the spray gun open. Your spray gun is equipped with a built-in trigger safety latch to guard against accidental trigger release and potentially dangerous high pressure spray. Rotate the safety latch to the locked position when not spraying.
- 15.) Do not clean this machine with its own spray. Cleaning should be done with a damp sponge with the electrical power turned OFF.

Grounding Instructions

This product must be connected to a grounded, metal, permanent wiring system; or an equipment-grounding conductor must be run with the circuit conductors and connected to the equipment-grounding terminal or lead on the product.

SAVE THESE INSTRUCTIONS

Machine Component Identification

157304

Ref #	Description
1	Inlet/Filter
2	On/Off Switch
3	High Pressure Outlet

Ref #	Description
4	Pump
5	Unloader
6	Motor

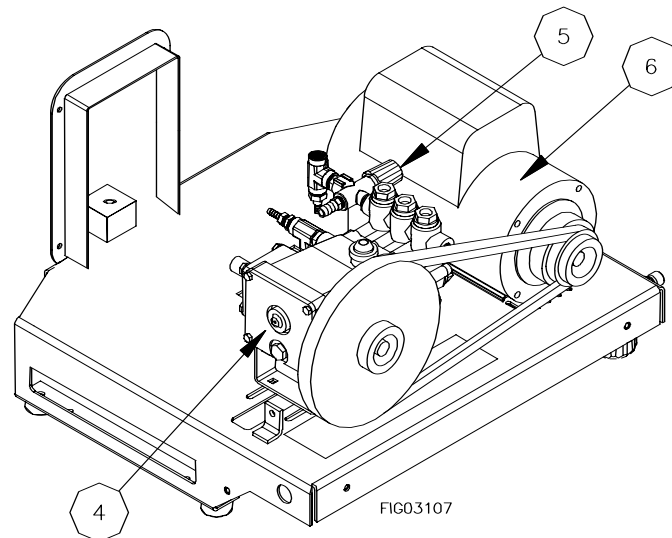
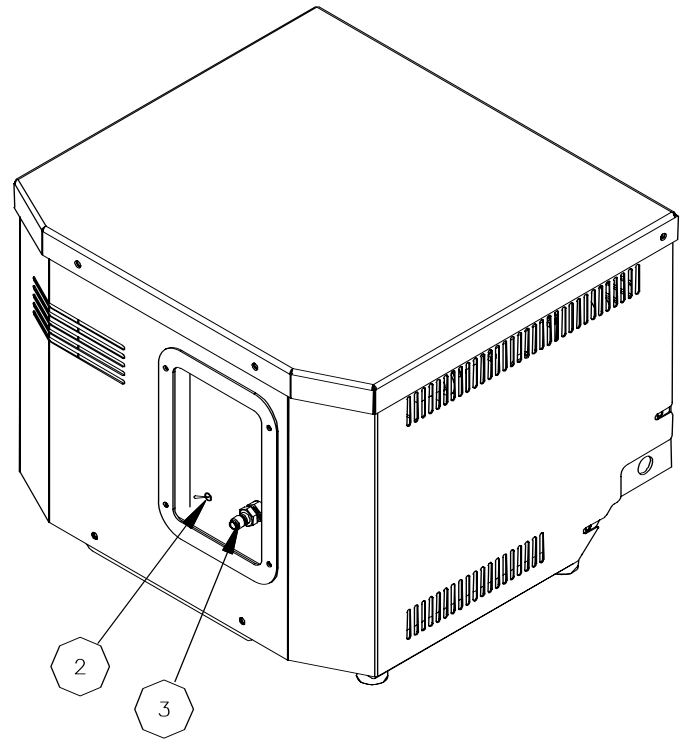
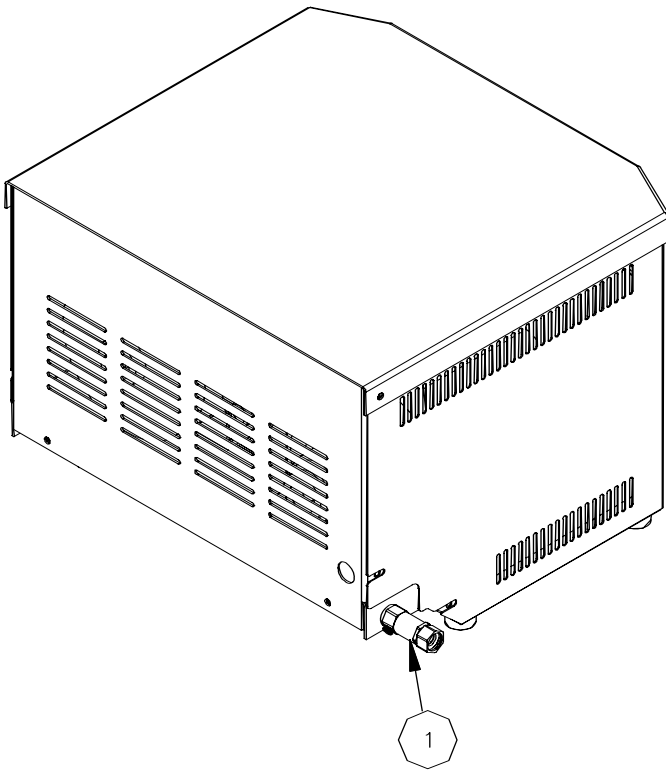

FIG03107

Installation Instructions

I.) Unpack

Separate and identify all components. Use the assembly instructions in this manual for assembly.

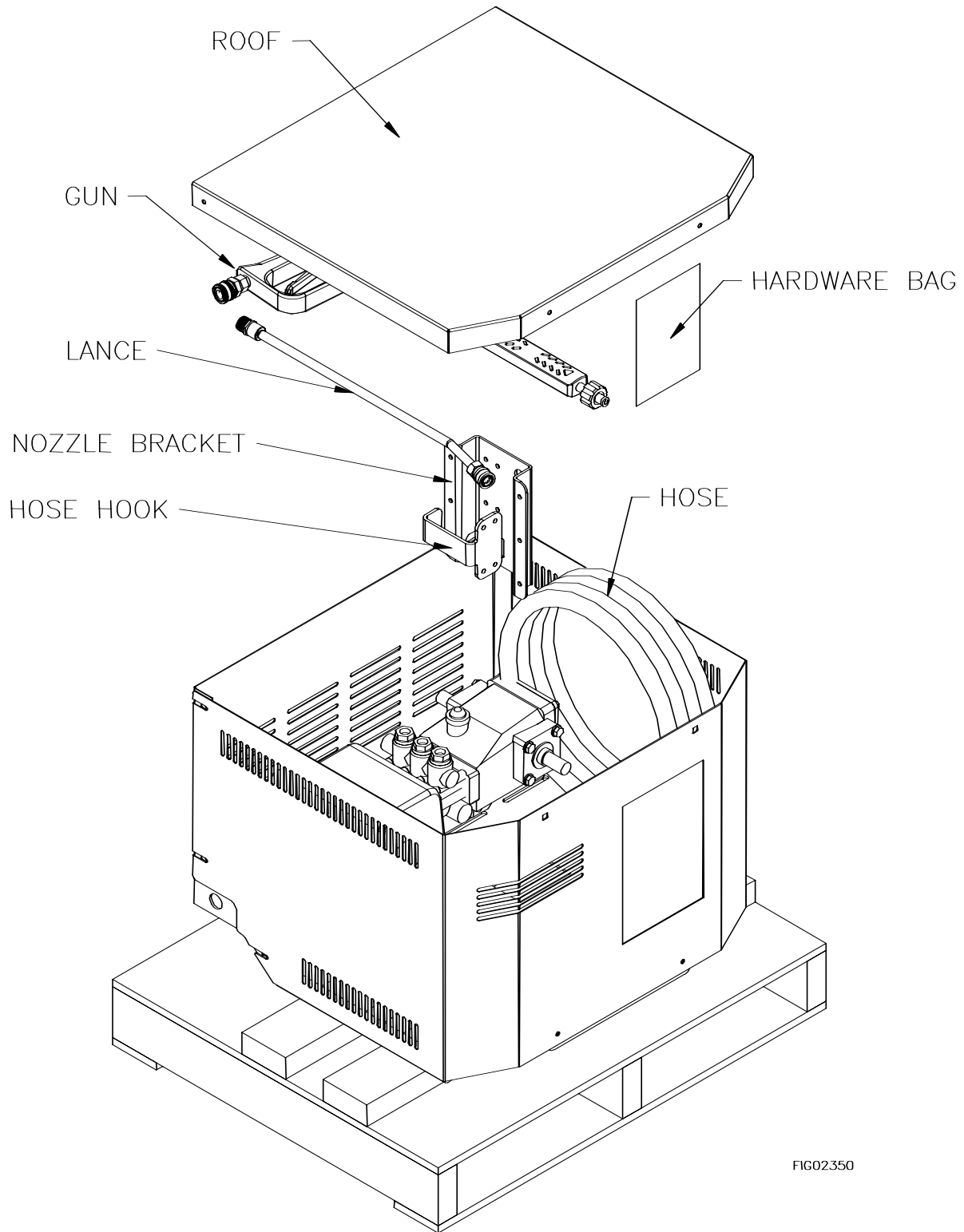

FIG02350

Hardware Bag

- Separate and identify all components. Use the assembly instructions in this manual for assembly.

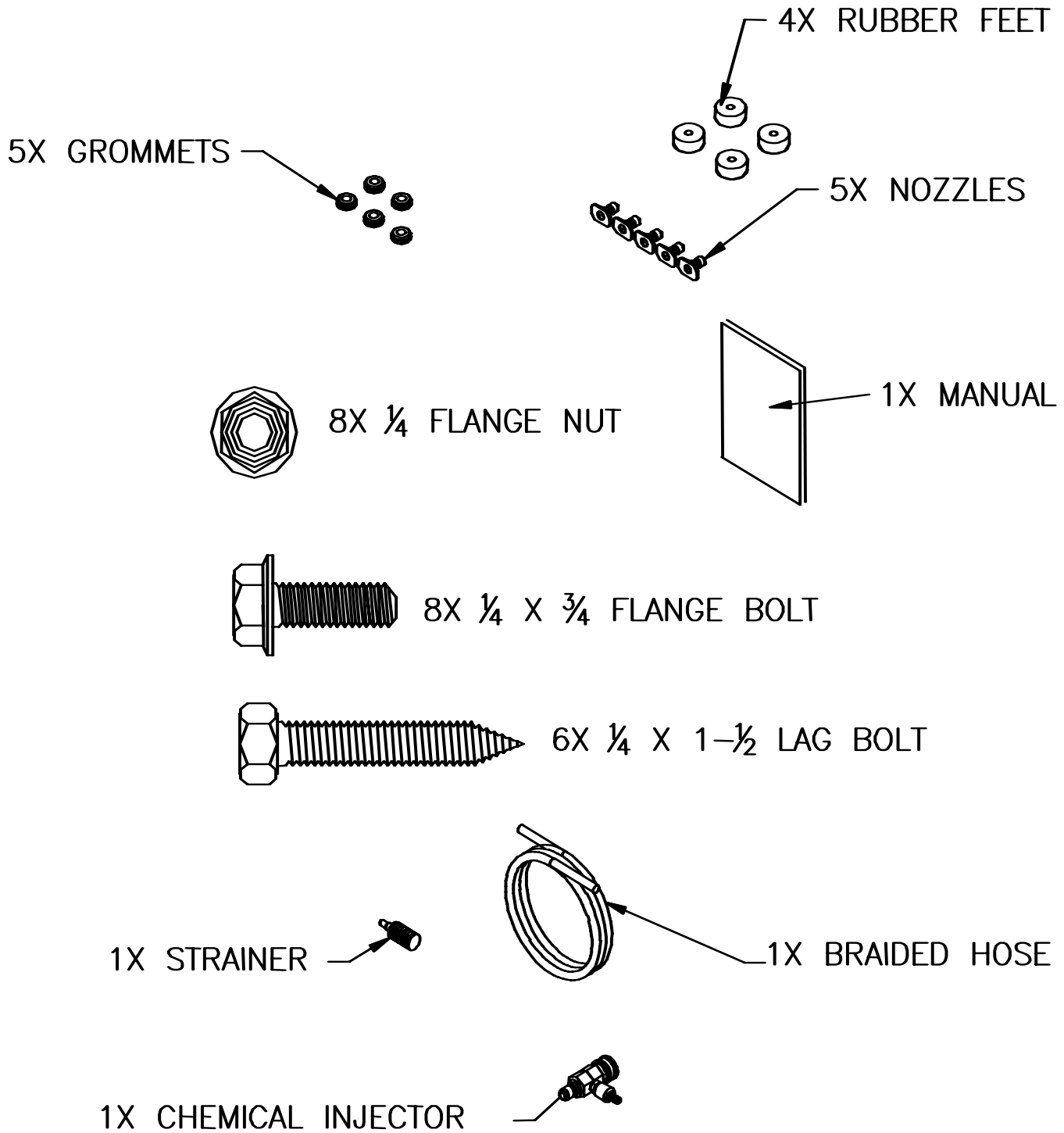
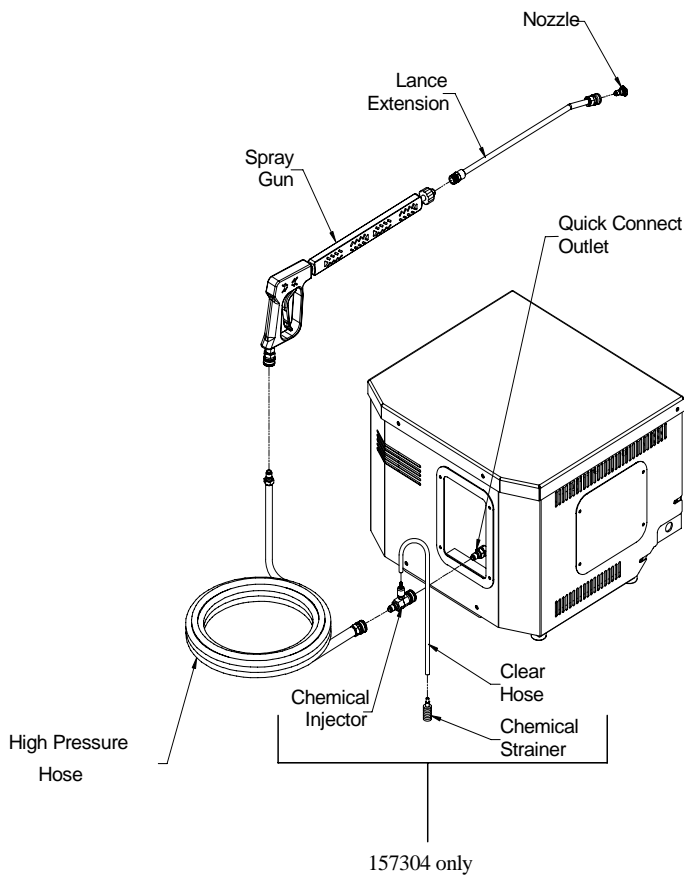

FIG03108

II.) Assembly Instructions

- A. 1. To spray chemical, insert the chemical injector into the quick connect outlet of the pressure washer as shown.
2. Connect the clear hose to the chemical strainer and to the inlet of the chemical injector. The chemical injector can remain installed at all times. Have hose exit base as shown below.
3. Install the pressure hose onto the chemical injector as shown, for 157304.
4. Connect the other end of the pressure hose to the spray gun as shown.
5. Connect the lance extension to the spray gun and insert the proper nozzle into the lance end.
6. Make sure all plumbing connections are tight.



7. Install four rubber feet onto base with four 1/4" x 3/4" flange bolts and four flange nuts. Use the same bolts to install cross members when installing the rubber feet.

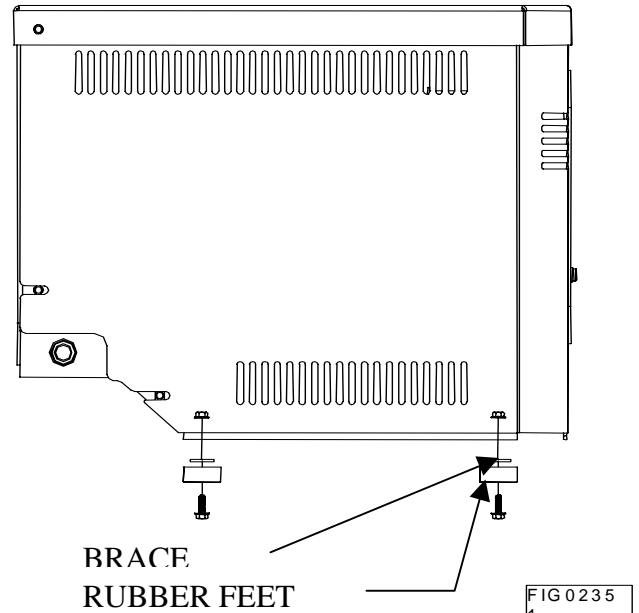

III.) Wiring Instructions

This pressure washer is shipped without a power cord and is intended to be hard wired into your electrical system. The following instructions will help you to hard wire this unit.

Electrical Requirements:

Item Number	Circuit Rating
157304	230V/30A

WARNING: Make sure to use a dedicated circuit that includes a GFCI. Consult local electrical code for connection requirements.

Step 1: Using a 3/8" wrench, remove the roof and the top of the electrical housing. (Front panel not shown for clarity.)

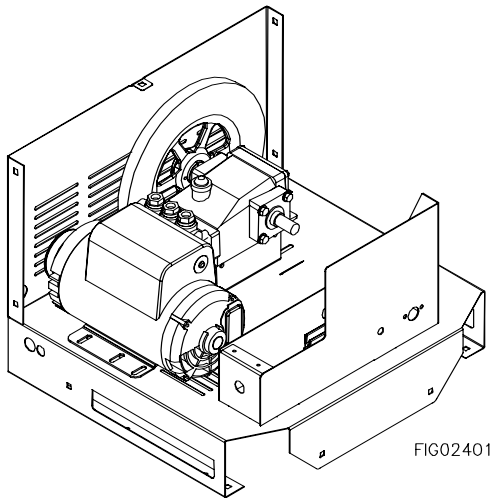

Step 2: Feed **power cord** through the strain relief nut on the bottom of the unit into the electrical housing.

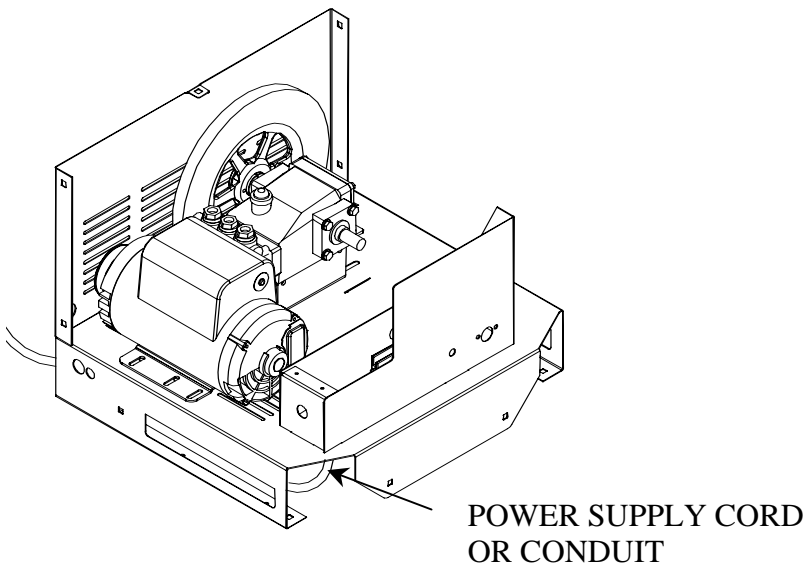

Step 3: Locate terminal block inside the electrical housing and attach wires (like colors should be across from each other).

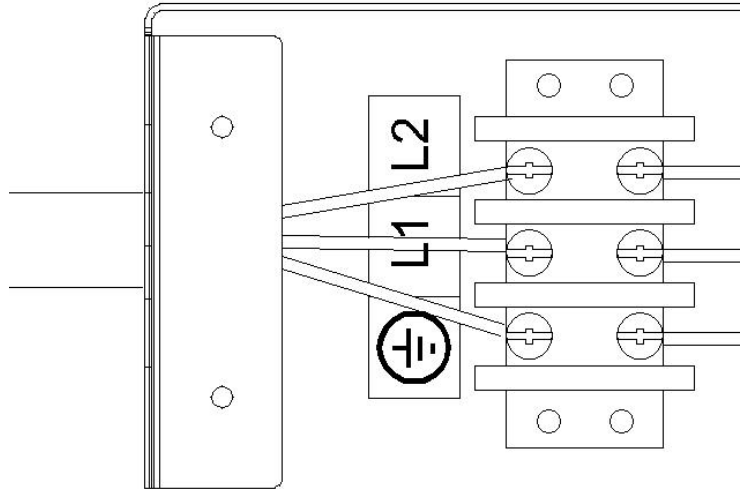

Step 4: Clamp cord in strain relief nut (thru the bottom of the panel) by turning nut clockwise.

Step 5: Re-attach the top of the electrical housing and the roof.

Operating Instructions

**Read and understand the entire manual before operating the pressure washer.
Follow these instructions every time you use the pressure washer.**

I.) Pre-Operation

- ☑ A.) Position the machine for easy access to all controls.
- ☑ B.) Position the machine on a solid surface, with less than a three degree slope, and so it is protected from external damage.
- ☑ C.) Make sure ambient lighting is sufficient for the surface you are cleaning to be seen with ease. Use artificial light if needed.
- ☑ D.) Check hoses, fittings, wand, trigger gun and electrical cords for signs of wear, cracks and looseness, and replace as required.
- ☑ E.) Check and clean the nozzle orifice.
- ☑ F.) Check and clean the water inlet screen and filter.
- ☑ G.) Read entire manual, especially the important safety instructions listed on page 2.
- ☑ H.) Check and maintain proper oil levels in the pump.

II.) Check Your Water Supply

- ☑ A.) Make sure the water supply is clean. Debris can cause excess pump wear and reduce performance. The maximum inlet water temperature is 140°F (60°C).
- ☑ B.) An insufficient water supply will damage your pump. Make sure the water supply is steady and is 20% over the rated flow of your pump. Use a stopwatch to time how long it takes to fill a 5 gallon bucket with your garden hose.
Example: If the rated flow is = 3gpm
Then required flow = $3 \times 1.20 = 3.6\text{gpm}$
 $5\text{gallons} / 3.6\text{gpm} = 1.39 \text{ minutes}$
 $1.39\text{min} \times 60\text{sec}/\text{min} = 83 \text{ seconds}$
Therefore, you must be able to fill a 5 gallon bucket in 83 seconds or faster.
- ☑ C.) The water supply garden hose must have an inside diameter of at least 5/8". If the hose is more than 100 ft. long, the diameter must be at least 3/4".
- ☑ D.) Never use a reservoir tank as a water source. This pressure washer is designed for a pressurized water source such as a city water faucet. Sucking water out of a tank may cause pump cavitation and damage to your pump. However, the inlet pressure of the pump must not exceed 115 psi (8 bar)
- ☑ E.) Always use a flexible rubber hose for your water supply. Do not use rigid piping.
- ☑ F.) Do not pump flammable liquids or liquids containing incompatible chemicals or solvents.

III.) Before Starting

WARNING: Check hoses, fittings, wand, gun and cords daily for signs of wear, cracks and looseness, and replace as required.

1. Connect water supply hose to the garden hose connector located on the side of the unit.
2. Connect high-pressure hose to quick connect outlet on front of the machine.
3. Connect spray gun to high-pressure hose.
4. If detergents will be used, only use detergents intended for pressure washers. Follow instructions on the detergent container.

IV.) To Start

DANGER: Do not point the spray wand at yourself or at any person. Bodily injury may result from water under high pressure.

WARNING: Wear eye, ear, hand, foot and skin protection at all times while operating this pressure washer.

IMPORTANT: The water must be turned on before starting. Running the pump dry will cause damage and void warranty.

1. Turn water supply ON.
2. Squeeze the trigger to allow air to purge from the system. (this step goes faster with the pressure nozzle removed)

V.) Attach Nozzle

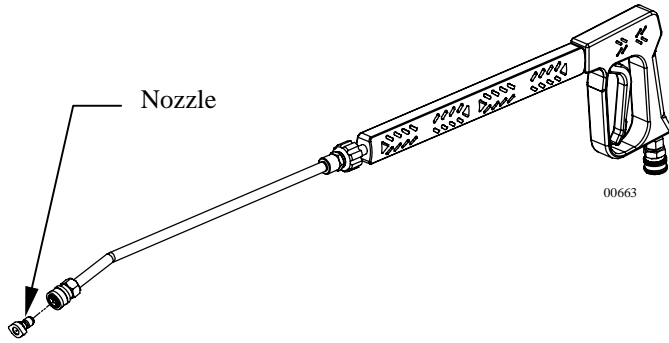

Color of Nozzle:	Spray Angle	Used For:
Red	0	Highest Impact
Yellow	15	Tough Stains/ Stripping
Green	25	General
White	40	Light Cleaning
Black		Low pressure/ Chemical Application

Your pressure washer is equipped with five nozzles. To install a nozzle simply pull back the collar and push the nozzle into the coupler. Once the connection is made, pull on the nozzle to assure a tight connection.

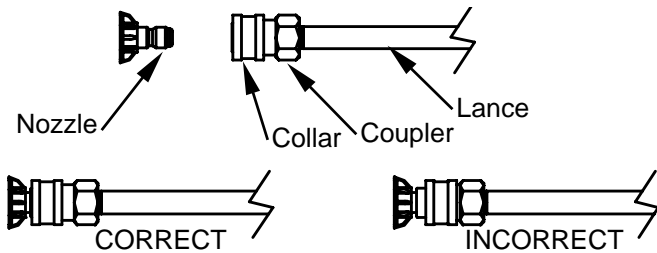

WARNING: Make sure the nozzle is correctly inserted. The nozzle may become a projectile if not inserted correctly. Do not attempt to use different types of nozzles that may not fit the coupler.

VI.) Turn the pump switch ON.

1. Make sure the hose is not kinked. A kinked hose will provide insufficient water supply to the pump and will reduce its life.

To Clean

WARNING: Wear eye, ear, hand, foot and skin protection at all times while operating this pressure washer.

DANGER: Do not point the spray wand at yourself or at any person. Bodily injury may result from water under high pressure.

IMPORTANT: Your spray gun is equipped with a built-in trigger safety latch to guard against accidental trigger actuation and potentially dangerous high pressure spray. Rotate the safety latch to the locked position when not spraying.

NOTE: Your pressure washer is equipped with a low pressure chemical injector. You do not need to use chemicals for every job, however, the proper chemical used for the proper application can speed up cleaning jobs tremendously.

WARNING: Only use North Star pressure washer chemicals or chemicals specifically formulated for pressure washers. Follow the chemical manufacturer's recommendations. Understand all safety precautions and first aid for all chemicals.

1. Insert chemical suction line and strainer into a container of detergent.
2. Completely open the chemical control knob located on the chemical injector.
3. Insert the chemical application nozzle (Black).
4. Turn the chemical control knob to adjust the chemical concentration. Spray detergent onto the surface and allow it to soak. Chemicals need time (dwell time) to work properly. Follow the chemical manufacturer's recommendations for dwell time.
5. Change back to high pressure by inserting the nozzle with the desired spray angle.
6. Hold the lance with two hands, have a sturdy stance.
7. Point lance at dirty surface and squeeze trigger.
8. Wash from the bottom to the top, using side to side motions. This washes away heavy dirt and allows the detergent to soak as you work toward the top.
9. Use the width of the spray pattern to wash in a wide path. Overlap spray paths for complete coverage.
10. The nozzle should be 12" to 24" from the work, closer for tough areas.

Max Chemical Ratio is 13:1

Caution: Be careful on painted or delicate surfaces, the pressure may damage the surface if the nozzle is too close.

11. Small parts should be washed in a basket so the pressure does not push them away. Larger, light weight parts should be clamped down.

12. The pressure washer is set to the maximum rated pressure when it leaves the factory. To change your pressure, turn the unloader knob found inside the machine counter clockwise.

WARNING: Do not alter the unloader valve's maximum pressure. Excess pressures could cause serious injury and/or pump damage. Any alteration other than turning the adjustment knob will void your warranty.

Maintenance Instructions

WARNING: *Unauthorized machine modification or use of non-approved replacement parts may cause personal injury and/or property damage and will void the manufacturer warranty.*

All mechanical equipment, no matter how well designed, will need repairs. A North Star pressure washer is no exception. At times, a North Star pressure washer may be inoperable because repairs are required. North Star Customer Service will assist in these repairs as needed, but if an inoperable pressure washer creates a major expense to your business then we strongly recommend the following:

1. Have someone on staff who is trained in the operation of the pressure washer and is capable of making minor repairs and performing all preventative maintenance procedures as outlined in the provided manuals.
2. Keep a stock of recommended service parts for maintenance and minor repairs.

Recommended Service Parts List

Following is a list of the service parts we recommend stocking.

Description	Part Number
Nozzle 5 Pack	778281
O-Ring for Hose	30784
Pump Oil	4043
Chemical Injector	31935
Spray Gun	319153
50' Pressure Hose	32276

Maintenance Mode

Before performing any maintenance on the pressure washer, it must be placed in maintenance mode.

- A.) Turn off water supply
- B.) Bleed water from system
- C.) Disconnect power by unplugging power cord and/or flipping circuit breaker OFF.

To Stop

1. If detergents were used, draw clean water through the detergent inlet line to purge detergent. Failure to do so may clog the chemical injector.
2. Turn the pump switch OFF.
3. Turn OFF the water supply.
4. Squeeze the trigger to relieve the system pressure.

Maintenance Schedule

What to Check	When To Check	What to Do
Inlet Filter	Each Use	Clean
Hoses	Each Use	Check for Wear
Bolts	Each Use	Check for Loose Bolts

Cleaning The Inlet Filter

WARNING: *Check whether dangerous chemicals have been used, and take precautions when handling filters.*

- A.) Unscrew inlet filter cap
- B.) Remove Inlet filter
- C.) Run water though to clean filter

Checking the Hoses

WARNING: *Do not use a finger or skin to check for leaks. Escaping fluid under pressure has sufficient force to penetrate the skin, causing serious injury. Do not operate the pressure washer if the hose is cracked, worn, or leaking.*

- A.) Check all hoses for leaks
- B.) Check all hoses of worn areas

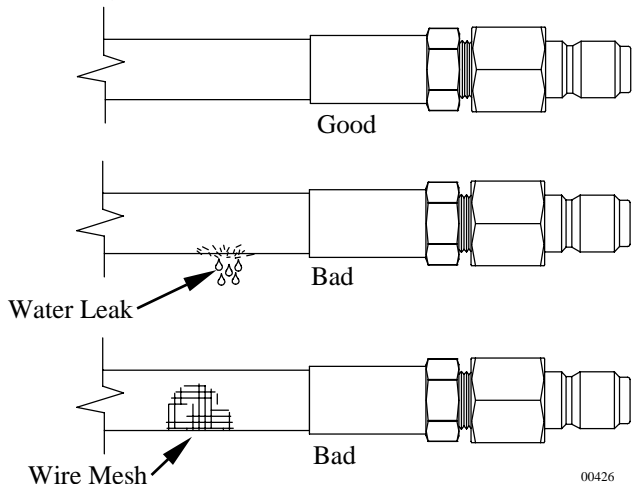

00426

Changing The Pump Oil

Change oil after first 50 hours, then every 3 months or 500 hours

- 1.) Remove oil drain plug
- 2.) Drain pump oil
- 3.) Replace oil drain plug
- 4.) Fill pump with Cat Item# 22158 pump c
- 5.) Fill half way up the sight glass.

Quantities Of Fluid

Pump	Type of Fluid	QTY
CAT 5CP3120	SAE 30**	17.0oz (0.41L)

**Non-Detergent Oil (order Cat Item# 22158 pump oil.)

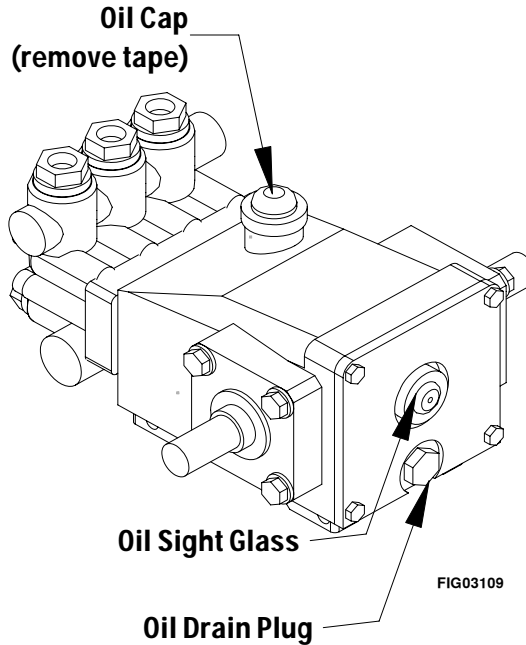

Long Term Storage

During cold weather, store the pressure washer indoors and move it outdoors before starting the motor. Follow these instructions to prevent the pump from freezing during storage.

Storage:

Before you store the pressure washer, make sure you do the following:

- 1.) Unplug the power cord from the pressure washer.
- 2.) Disconnect high pressure and garden hose.

Winter Storage:

Items needed: 12" piece of garden hose or equivalent, funnel and RV antifreeze (approximately 6 oz.)

- 1.) Follow the storage instructions listed above.
- 2.) Attach the garden hose with funnel to the pump inlet (see illustration).
- 3.) Pour RV antifreeze into the funnel, turn on the motor until antifreeze comes out the pump outlet.
- 4.) Drain all water from the high pressure hose. Depress trigger on gun and drain all water out of gun/lance.

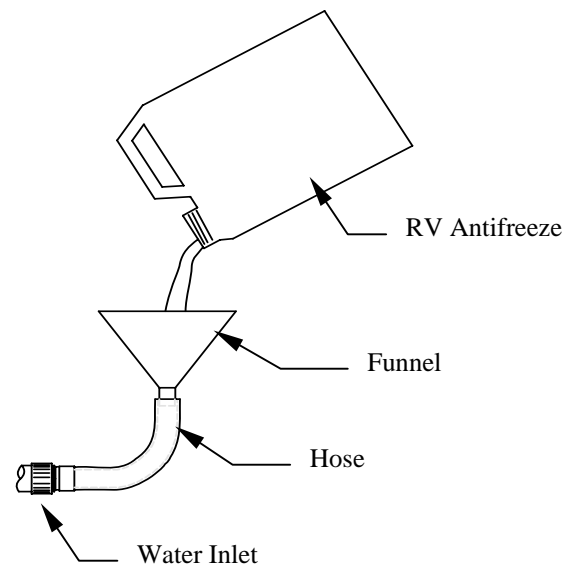

Troubleshooting Guide

Pressure Washer Will Not Run At All - No Power

<i>Causes</i>	<i>Solutions</i>
Machine turned OFF	Turn Pump switch ON
Line circuit breaker tripped	Check for tripped circuit breaker in building

Circuit Breaker Trips

<i>Causes</i>	<i>Solutions</i>
Voltage too low	Check the voltage
Circuit Breaker Overloaded	Make sure there is no other equipment using the same circuit.
Pressure set too high	Check/adjust pressure setting on unloader.

Pressure Washer Runs But Will Not Spray Water

<i>Causes</i>	<i>Solutions</i>
Trigger released	Squeeze trigger
Clogged nozzle	Clean nozzle orifice

Low Pressure

<i>Causes</i>	<i>Solutions</i>
Low water flow	Make sure the water supply is more than 4 gpm
Partially clogged or damaged nozzle	Clean or replace nozzle

Pressure Washer Runs But Surges Or Cycles While In Bypass

<i>Causes</i>	<i>Solutions</i>
Leak between unloader and gun.	Check all connections between unloader and gun for leaks. Tighten loose components and replace damaged components.
Gun leaking internally	Replace spray gun

Poor Or No Detergent Supply

<i>Causes</i>	<i>Solutions</i>
Soap control knob set too low.	Adjust soap control knob
Inadequate detergent supply	Refill detergent container. Make sure the chemical strainer is fully submerged
High pressure hose too long	Use less hose. Move machine closer to the work.
Chemical strainer or hose clogged	Clean the strainer. Always start with a clean detergent container
Clogged injector	Clean injector check valve or replace injector. Run clean water through the injector after each use.

Any Questions, Comments, Problems or Parts Orders
Call NorthStar Product Support 1-800-270-0810

157304
Parts Breakdown

Rev G

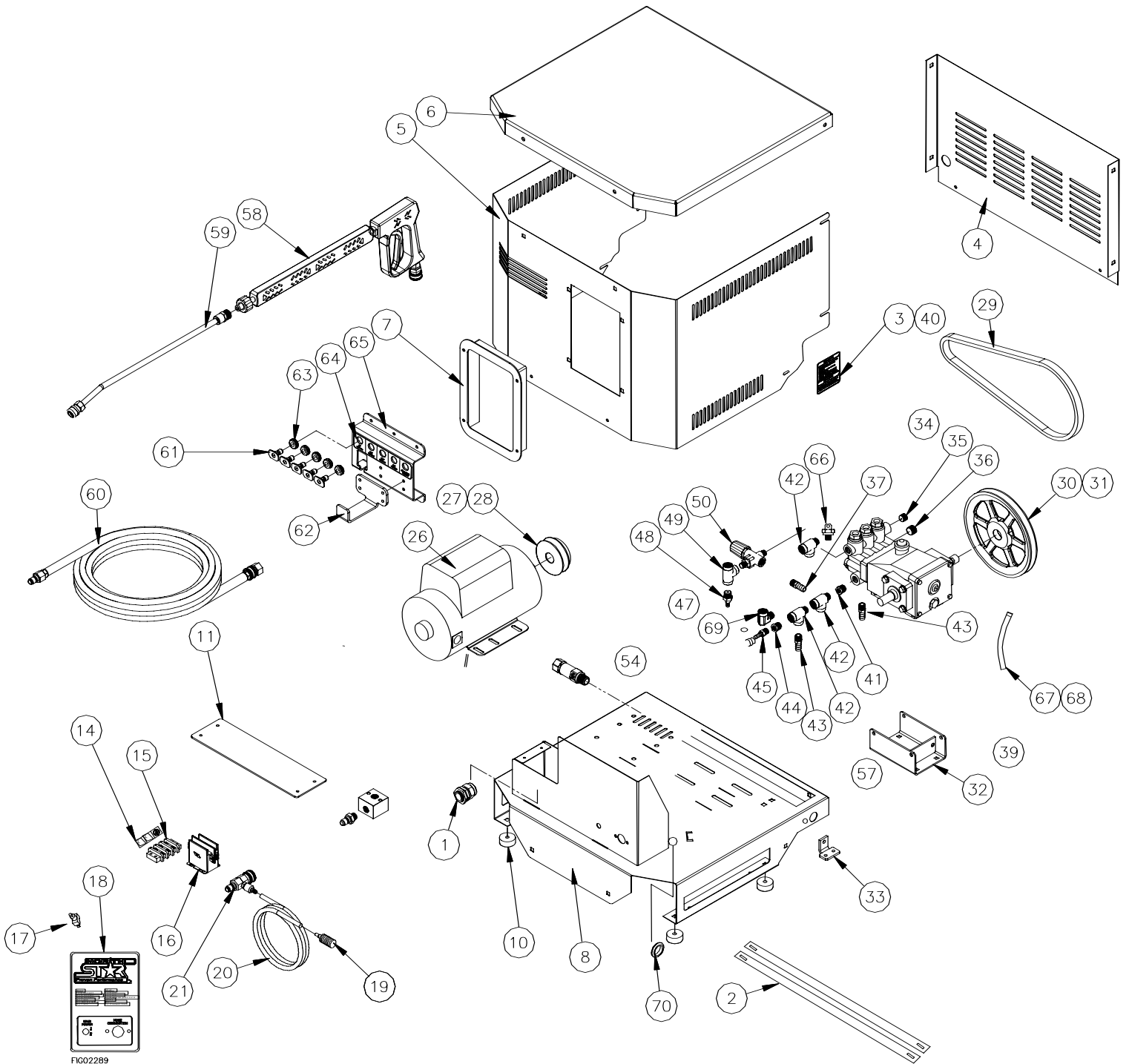

FIG02289

157304
Parts Breakdown

Rev G

ITEM	PART#	DESCRIPTION	QTY
1	777123	Strain relief, 10 GA. cord	1
2	778294	Brace	2
3	33555	Warning decal	1
4	778268	Rear panel	1
5	778357	Front panel	1
6	778280	Roof	1
7	33543	Insert	1
8	778221	Base	1
10	2215	Rubber bumper	4
11	778214	Top, electrical housing	1
14	33556	Terminal block decal	1
15	34200	Terminal block	1
16	778152	DP Contactor	1
17	777855	Toggle switch	1
18	778244	Panel decal	1
19	2212	Chemical strainer	1
20	777165	Chemical hose	48"
21	31934	Chemical injector	1
22	777409	Unloader block	1
23	777913	3/8 QC nipple	1
24	36290	Heyco bushing	1
25	778147	Motor cord	1
26	778670	Motor, 5hp, 240V	1
27	33561	Sheave, BK34	1
28	33562	3/4" bushing	1
29	778240	Belt, 49" grip notch	1
30	778225	Sheave, BK130H	1
31	313100	20mm bushing	1
32	34325	Pump mount	1
33	777179	Tension block	1
34	31310	Cat pump	1
35	777837	3/8 plug	1
36	30511	1/2" plug NPT	1

ITEM	PART#	DESCRIPTION	QTY
38	2264	1/2" black bypass hose	18"
39	2263	1/2" hose clamp	2
40	35189	Warning rotating decal	1
41	30048	1/2 x 3/8 reducer	1
42	777347	3/8 street tee	3
43	777839	3/8npt x 1/2 hose barb	3
44	777338	3/8 x 1/4 reducer	1
45	777340	1/4 npt x 1/4 hose barb	1
46	777165	1/4" pvc hose	12"
47	777834	1/4" hose clamp	2
48	38584	Easy starter valve	1
49	777411	3/8 tee	1
50	777800	Unloader	1
51	777378	3/8 x 18" hose assembly	1
52	35169	Inlet filter	1
53	305267	Strain relief nut	1
54	777645	1/2" F npt x 1/2 hose barb	1
55	17141	Hose clamp	1
56	2264	1/2" black inlet hose	36"
57	2263	1/2" hose clamp	2
58	31915	Gun with lance	1
59	31930	18.5" lance extension	1
60	38525	50' quick couple hose	1
61	778281	Nozzle, 5 pack, #2.5	1
62	777184	Hose hook	1
63	777111	Rubber grommet	5
64	777217	Nozzle decal	1
65	777183	Nozzle/lance bracket	1
66	30148	Thermal Protector, 3/8	1
67	777165	Chemical hose	6"
68	777834	1/4" hose clamp	1
69	777410	3/8" street elbow	1
70	31985	Grommet	1

Pump Breakdown

5CP3120

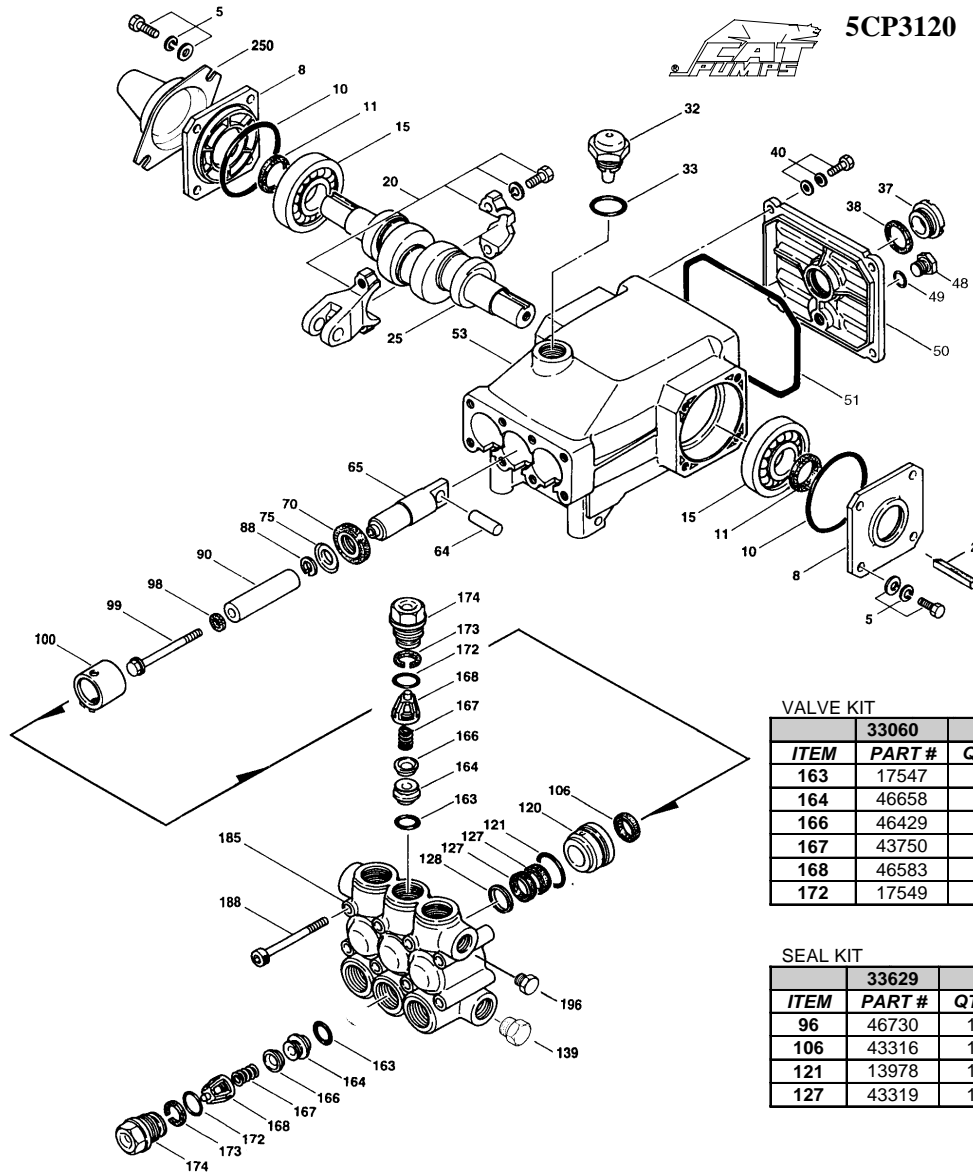

VALVE KIT

33060		
ITEM	PART #	QTY
163	17547	2
164	46658	2
166	46429	2
167	43750	2
168	46583	2
172	17549	2

SEAL KIT

33629		
ITEM	PART #	QTY
96	46730	1
106	43316	1
121	13978	1
127	43319	1

ITEM	PART #	DESCRIPTION	QTY
2	30057	Key (M6)	1
5	96031	Screw, Sem HC M8x16	8
8	46910	Cover Bearing	2/1
10	14028	O-Ring \, Bearing Cover	2
11	43222	Seal, Oil, Crankshaft	2
15	14480	Bearing	2
20	46743	Rod, Connecting Assembly	3
25	46928	Crankshaft, Dual End	1
30	48224	Cover, Bearing Blind	1
31	828710	Protector, Oil Cap	1
32	46798	Cap, Oil Filler, Domed	1
33	14179	O-Ring, Oil Filler Cap	1
37	43987	Gauge, Oil, Bubble	1
38	44428	gasket, Flat, Oil Gauge	1
40	92519	Screw, Sems HHC (M6x16)	4
48	25625	Plug, Drain	1
49	23170	O-Ring, Drain Plug	1
50	46940	Cover, Crankcase	1
51	14044	O-Ring, Crankcase Cover	1
53	46912	Crankcase	1
64	46746	Pin, Rist	3
65	46747	Rod, Plunger	3
70	46838	Seal, Oil, Crankcase	3
75	43900	Slinger, Barrier	3

ITEM	PART #	DESCRIPTION	QTY
88	45697	Washer, Keyhole (M18)	3
90	46884	Plunger (M50)	3
98	46730	Washer, Seal	3
99	46729	Retainer, Plunger w/Stud (M7)	3
100	46749	Retainer, Seal	3
106	43316	Seal, LPS w/S-Spg	3
120	46888	Case, Seal, Press-in-style	3
121	13978	O-Ring, Seal Case	3
127	43319	V-Packing	6
128	46618	Adapter, Male	3
139	22179	Plug, Inlet (1/2")	1
163	17547	O-Ring, Seat	6
164	46658	Seat	6
166	46429	Valve	6
167	43750	Spring	6
168	46583	Retainer, Spring	6
172	17549	O-Ring, Valve Plug	6
173	48365	Back-up-ring, Valve Plug	6
174	45900	Plug, Valve	6
185	46886	Manifold, Head	1
188	87872	Bolt, HSH (M8x70), Manifold Head	8
196	22187	Plug, Discharge (3/8")	1
250	118672	Protector, Shaft	1

Wiring Diagram

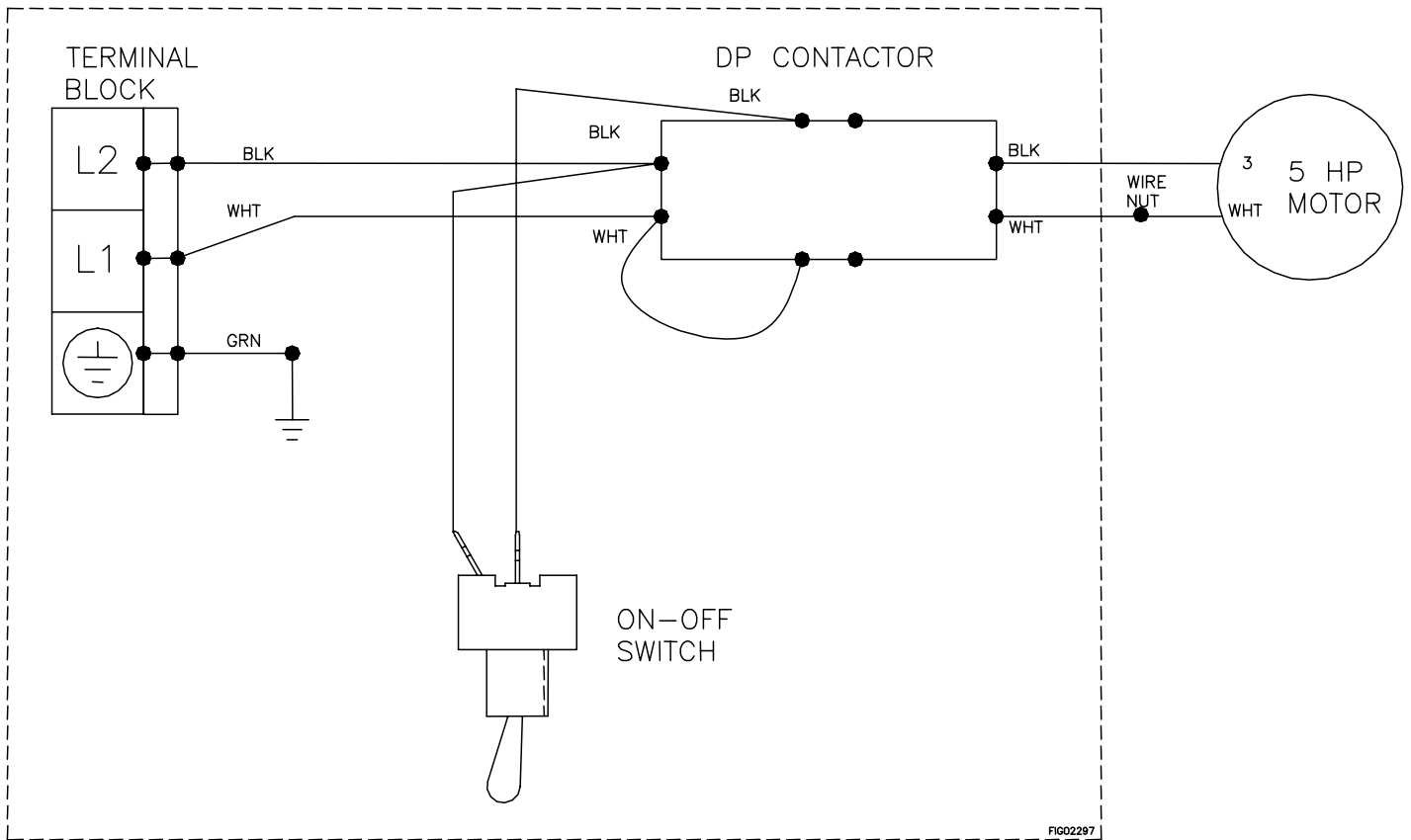

Limited Warranty

Dear Valued Customer:

The NorthStar Product you just purchased is built with the finest material and craftsmanship. Use this product properly and enjoy the benefits from its high performance. By purchasing a NorthStar product, you show a desire for quality and durability.

Like all mechanical equipment this unit requires a due amount of care. Treat this unit like the high quality piece of machinery it is. Neglect and improper handling may impair its performance. Please thoroughly read the instructions and understand the operation before using your product.

Limited Warranty

NorthStar shall warranty any piece of equipment manufactured, or parts of equipment manufactured, to be free from defects in material or workmanship for a period of 2 years from the date of purchase by user. This warranty applies to the original purchaser of the equipment and is non transferable. Verification of purchase is the responsibility of the buyer. Parts will be replaced or repaired at no charge, except when the equipment has failed due to lack of proper maintenance. Any misuse, abuse, alteration or improper installation or operations will void warranty. Determining whether a part is to be replaced or repaired is the sole decision of NorthStar.

NOTE: Some services performed by parties other than NorthStar may void warranty.

This warranty covers parts only. It will not provide for replacement of complete products due to defective parts. Components not manufactured by NorthStar such as engines are guaranteed by their manufacturer and can be serviced at factory-authorized locations near you. Any costs incurred due to replacement or repair of items outside of a NorthStar approved facility is the responsibility of the buyer and not covered under warranty. NorthStar can supply you with the service center location in your area.

This warranty specifically excludes the following; failure of parts due to damage caused by accident, fire, flood, windstorm, acts of God, applications not approved by NorthStar in writing, corrosion caused by chemicals, use of replacement parts which do not conform to manufacturer's specifications, and damage caused by vandalism. Additional exclusions: loss of running time, inconvenience, loss of income, or loss of use, including any implied warranty of merchantability of fitness for a specific use.

Warranty does not cover items subject to normal wear such as tires, receptacles or any part subject to direct physical contact by the public. This warranty does not cover any personal injury or damage to surrounding property caused by failure of any part.

This warranty is in lieu of any other warranty expressed or implied and NorthStar assumes no other responsibility or liability outside that expressed within this warranty.

Please fill in the following information and have it on hand when you call in a warranty claim.

Customer Number: _____

Date of Purchase: _____

NorthStar Serial Number: _____

Item Number: _____



Manufactured by
Northern Tool + Equipment Co.,
2800 SouthCross Drive West
P.O. Box 1499 Burnsville, MN 55337-0499