

## 3310V HANDLEBAR PARTS

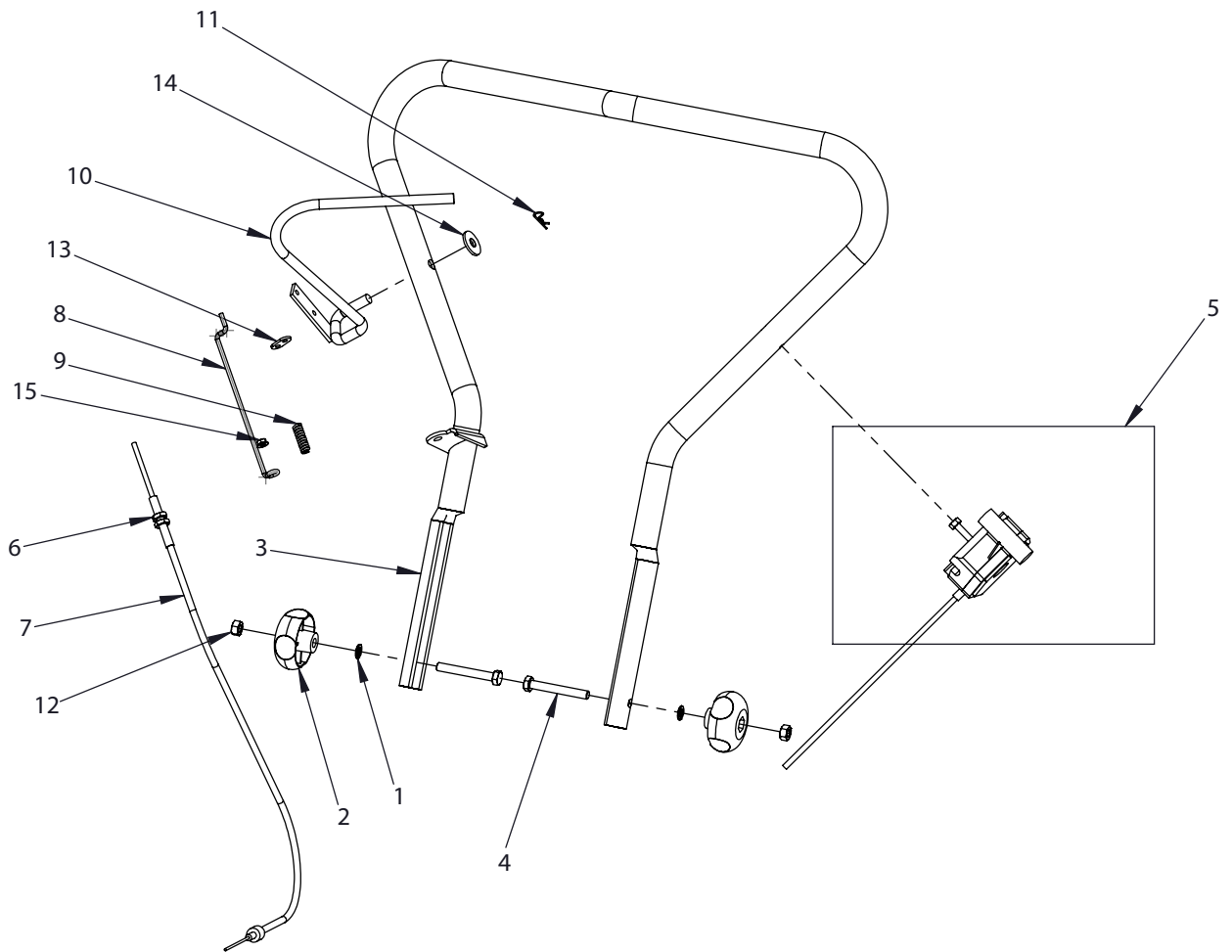

REF. NO.	PART #	DESCRIPTION	QTY.
1	331039	FLAT WASHER 8	2
2	331047	HANDLE KNOB	2
3	331046	HANDLE ASSEMBLY	1
4	331099	SCREW, M8X55	2
5	3310119	KIT, THROTTLE CONTROL WITH HARDWARE (includes 7 items)	1
6	4655	NUT M8 HEX JAM	2
7	331018	CLUTCH CABLE ASSEMBLY	1

REF. NO.	PART #	DESCRIPTION	QTY.
8	331020	CLUTCH LEVER	1
9	331081	SPRING	1
10	331019	CLUTCH HANDLEBAR ASSEMBLY	1
11	331005	B PIN, 2.5 X 37	1
12	331054	LOCKNUT M8	2
13	331072	BRACKET LEVER AND CABLE	1
14	331041	WASHER, M8 X 22	1
15	3248	NUT HEX FLANGE M5 X 8	1

**3310V MOTOR MOUNT & HOOD PARTS**

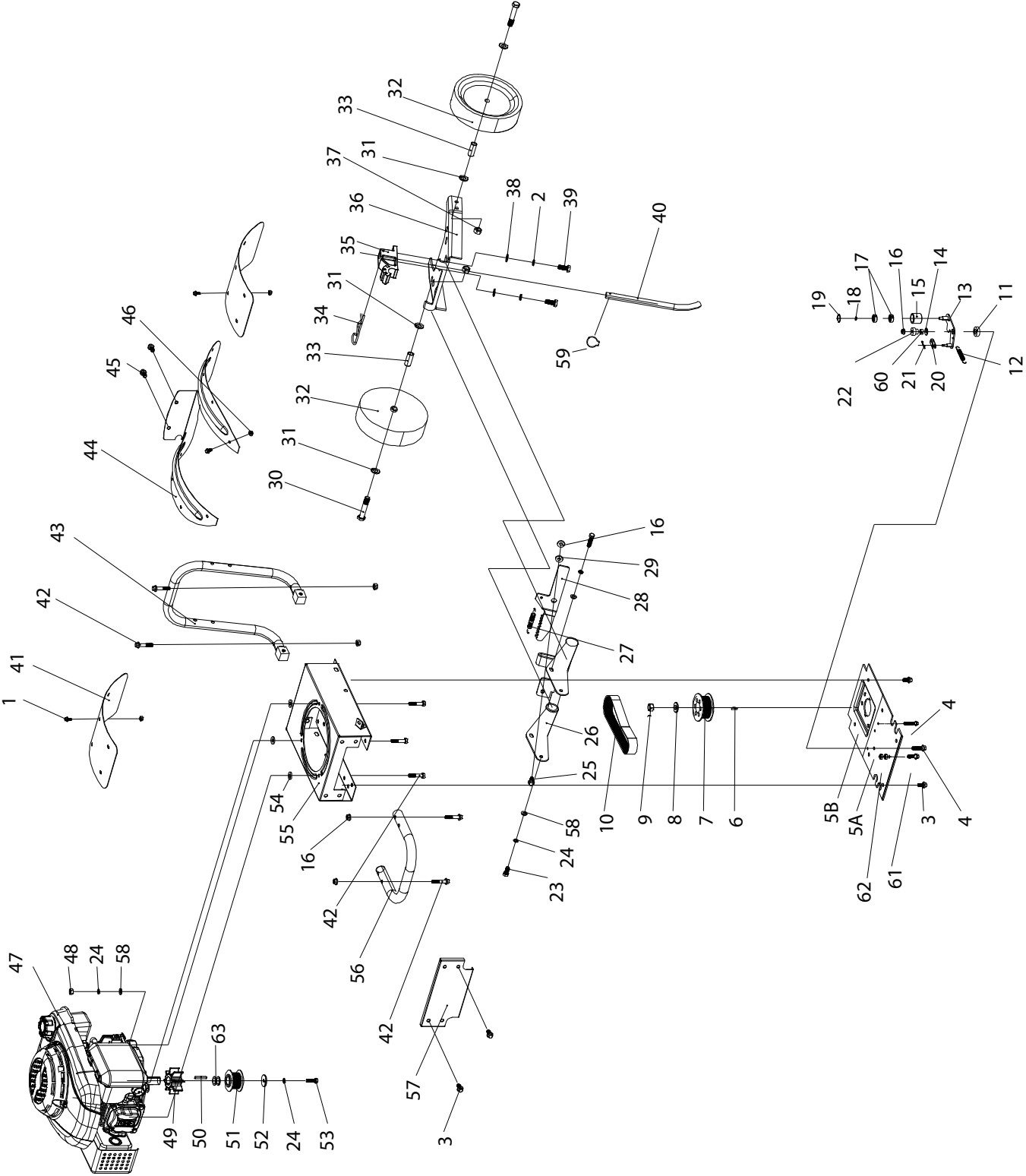



**3310V MOTOR MOUNT & HOOD PARTS**

REF. NO.	PART #	DESCRIPTION	QTY.
1	331062	OUTER HEX FLANGE BOLT M6 X 12	12
2	331083	SPRING WASHER 10	34
3	331066	OUTER HEX FLANGE BOLT M8 X 18	10
4	3310123	OUTER HEX FLANGE BOLT M8 X 60	2
5A	331027A	ENGINE SEAT ASSEMBLY FRONT	1
5B	331027B	ENGINE SEAT ASSEMBLY REAR	1
6	331077	SEMICIRC KEY 4 X 6.5 X 16	1
7	331010	BIG BELT WHEEL	1
8	331037	FLAT WASHER 12 X 28 X 3	1
9	331052	LOCKNUT M12	1
10	331008	BELT 10PD457	1
11	331086	TENSION SHAFT BUSHING	1
12	331026	DRAFT SPRING	1
13	331017	CLUTCH ARM ASSEMBLY	1
14	331041	FLAT WASHER 8 X 22 X 2	1
15	331087	TENSION WHEEL	1
16	331054	LOCKNUT M8	8
17	331024	DEEP GROOVE BALL BEARING 628	2
18	331016	CIRCLIP 8	1
19	331014	CIRCLIP 24	1
20	331013	CABLE CLIP	1
21	331091	UNCORK PIN	1
22	331009	BELT BLOCK BUSHING	1
23	331060	OUTER HEX BOLT M8 X 20	2
24	331084	SPRING WASHER 8	12
25	331067	OUTER HEX FLANGE BOLT M8 X 22	1
26	331032	FIXED SEAT	1
27	331026	DRAFT SPRING	1
28	331001	ADJUSTABLE PLATE	1
29	331003	ADJUSTABLE SHAFT BUSHING	1
30	331094	WHEEL BOLT	2
31	331036	FLAT WASHER 10 X 22 X 2	4
32	331093	WHEEL	2
33	331096	WHEEL SHAFT BUSHING	2
34	331007	B PIN 4 X 110	1

REF. NO.	PART #	DESCRIPTION	QTY.
35	331002	ADJUSTABLE SEAT	1
36	331095	WHEEL SEAT	1
37	331052	LOCKNUT M12	2
38	331035	FLAT WASHER 10	2
39	331058	OUTER HEX BOLT M10 X 25	2
40	331025	DEPTH REGULATOR	1
41	331029	EXTENDED PLATE	2
42	331068	OUTER HEX FLANGE BOLT M8 X 40	9
43	331045	HANDLE ARM ASSEMBLY	1
44	331031	FENDER	1
45	331065	OUTER HEX FLANGE BOLT M8X16	2
46	331033	FLANGE LOCKNUT	8
47	31337	ENGINE 159CC VERT. VIPER	1
48	331070	OUTER HEX NUT M8	3
49	331030	FAN	1
50	331034	FLAT KEY	1
51	331080	SMALL BELT WHEEL	1
52	331040	FLAT WASHER 10 X 32 X 4	1
53	331012	BOLT, HEX 3/8 X 1	1
54	331048	HEAT INSULATION PLATE	3
55	331028	ENGINE SEAT COVER ASSEMBLY	1
56	331085	STEEL HANDLE	1
57	331043	FRONT COVER BOARD	1
58	331039	FLAT WASHER 8	15
59	3310103	RING CLIP	1
60	3310120	CASE BUSHING	1
61	3310121	OUTER HEX BOLT M6 X 25	1
62	331053	LOCKNUT M6	2
63	3310122	WASHER SHIM SPACER	2*

\* Quantity varies based on pulley alignment requirements

**TINE & TRANSMISSION PARTS**

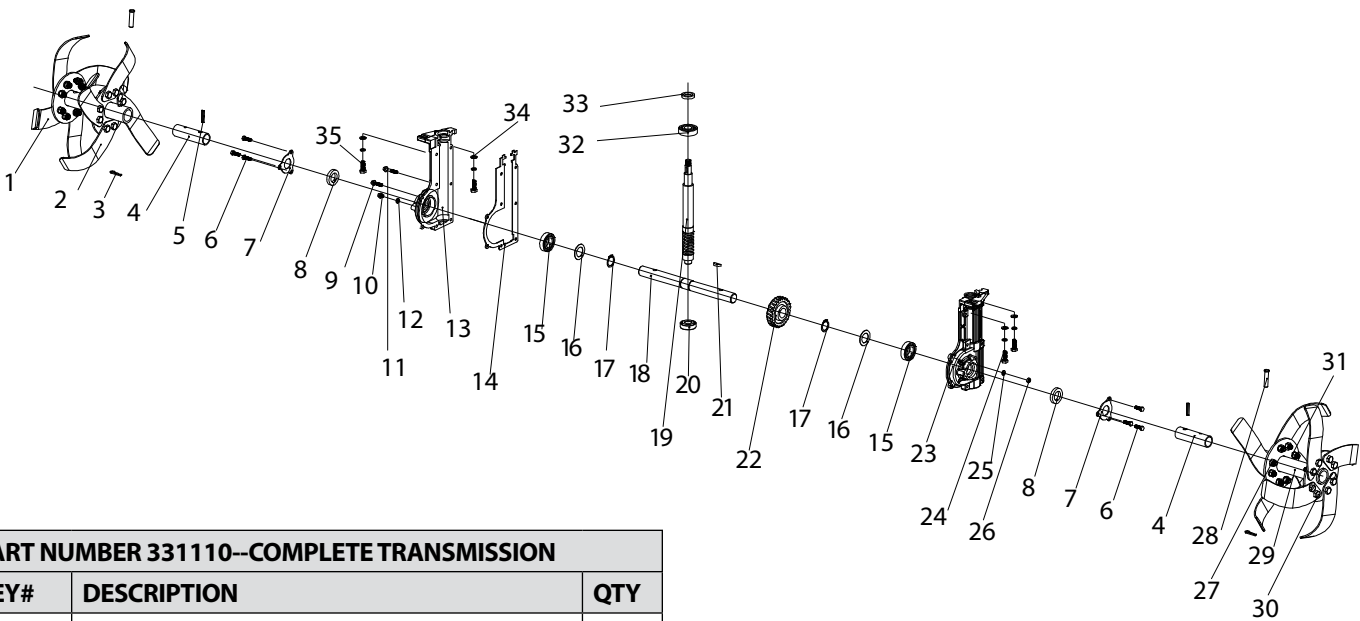

**PART NUMBER 331110--COMPLETE TRANSMISSION**

KEY#	DESCRIPTION	QTY
4	OUTPUT SHAFT BUSHING	2
5	SPRING PIN 6 X 28	2
6	OUTER HEX FLANGE BOLT M6 X 12	12
7	OIL SEAL CAP	2
8	FRAMEWORK OIL SEAL 25 X 40 X 7	2
9	OUTER HEX FLANGE BOLT M6 X 25	5
10	OUTER HEX FLANGE BOLT M10 X 1 X 14	2
11	OUTER HEX FLANGE BOLT M6 X 35	4
12	WASHER ASSEMBLY 10	2
13	LEFT CASE	1
14	GASKET	1
15	DEEP GROOVE BALL BEARING 6005	2
16	ADJUSTABLE WASHER	2
17	CIRCLIP 25	2
18	OUTPUT SHAFT	1
19	WORM	1
20	CONE NEEDLE BEARING 30203	1
21	SEMICIRCULAR KEY 5 X 9 X 22	2
22	WORM WHEEL	1
23	RIGHT CASE	1
25	FLAT WASHER 6	9
26	LOCKNUT M6	9
32	DEEP GROOVE BALL BEARING 6204	1
33	FRAMEWORK OIL SEAL 20 X 32 X 6	1

**PARTS AVAILABLE SEPARATELY**

REF. NO.	PART #	DESCRIPTION	QTY.
1	331049	LEFT BLADE	8
2	331073	RIGHT BLADE	8
3	311006	B PIN 2X46	2
6	331062	OUTER HEX FLANGE BOLT M6 X 12	12
7	331055	OIL SEAL CAP	2
8	3310105	FRAMEWORK OIL SEAL 25 X 40 X 7	2
14	331044	GASKET	1
24	3310124	OUTER HEXAGON BOLT M8 X 30	3
27	331056	OUTER HEXAGON BOLT M10 X 1	32
28	331079	SHAFT PIN 10 X 50	2
29	331011	BLADE SHAFT ASSEMBLY	2
30	331057	OUTER HEX BOLT M10 X 1 X 25	32
31	331083	SPRING WASHER 10	34
33	331042	FRAMEWORK OIL SEAL 20 X 32 X 6	1
34	331039	FLAT WASHER 8	4
35	3310104	OUTER HEXAGON BOLT M8 X 80	1