

HONDA

Power

Equipment

Owner's Manual
SNOWBLOWER
HS724·HS928·HS1132

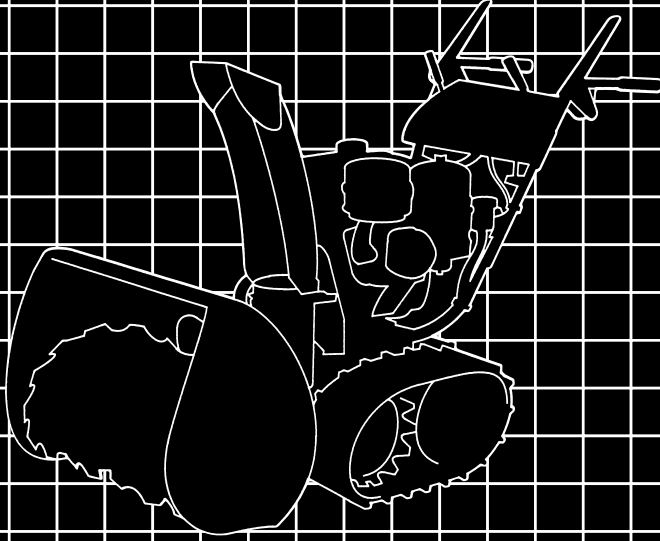



WARNING:



The engine exhaust from this product contains chemicals known to the State of California to cause cancer, birth defects or other reproductive harm.

Keep this owner's manual handy, so you can refer to it any time. This owner's manual is considered a permanent part of the snowblower and should remain with the snowblower if resold.

The information and specifications included in this publication were in effect at the time of approval for printing. Honda Motor Co., Ltd. reserves the right, however, to discontinue or change specifications or design at any time without notice and without incurring any obligation whatever.

INTRODUCTION

Congratulations on your selection of a Honda snowblower. We are certain you will be pleased with your purchase of one of the finest snowblowers on the market.

We want to help you get the best results from your new snowblower and to operate it safely. This manual contains the information on how to do that; please read it carefully.

As you read this manual, you will find information preceded by a **NOTICE** symbol. That information is intended to help you avoid damage to your snowblower, other property, or the environment.

We suggest you read the warranty policy to fully understand its coverage and your responsibilities of ownership. The warranty policy is a separate document that should have been given to you by your dealer.

When your snowblower needs scheduled maintenance, keep in mind that your Honda servicing dealer is specially trained in servicing Honda snowblowers. Your Honda servicing dealer is dedicated to your satisfaction and will be pleased to answer your questions and concerns.

Best Wishes,
Honda Motor Co., Ltd.

INTRODUCTION

A FEW WORDS ABOUT SAFETY

Your safety and the safety of others are very important. And using this snowblower safely is an important responsibility.

To help you make informed decisions about safety, we have provided operating procedures and other information on labels and in this manual. This information alerts you to potential hazards that could hurt you or others.

Of course, it is not practical or possible to warn you about all the hazards associated with operating or maintaining a snowblower. You must use your own good judgment.

You will find important safety information in a variety of forms, including:

- **Safety Labels** — on the snowblower.
- **Safety Messages** — preceded by a safety alert symbol  and one of three signal words, DANGER, WARNING, or CAUTION.

These signal words mean:

 **DANGER**

You WILL be KILLED or SERIOUSLY HURT if you don't follow instructions.

 **WARNING**

You CAN be KILLED or SERIOUSLY HURT if you don't follow instructions.

 **CAUTION**

You CAN be HURT if you don't follow instructions.

- **Safety Headings** — such as *IMPORTANT SAFETY INFORMATION*.
- **Safety Section** — such as *SNOWBLOWER SAFETY*.
- **Instructions** — how to use this snowblower correctly and safely.

This entire book is filled with important safety information — please read it carefully.

CONTENTS

SNOWBLOWER SAFETY	5
IMPORTANT SAFETY INFORMATION	5
SAFETY LABEL LOCATIONS	8
CONTROL & FEATURES	9
COMPONENT & CONTROL LOCATIONS	9
CONTROLS.....	11
Fuel Valve Lever	11
Engine Switch.....	11
Fuel Gauge.....	11
Chute Crank	12
Starter Grip	12
Throttle Lever	12
Choke Knob	13
Shift Lever.....	13
Discharge Deflector Lever	14
Foot Pedal	14
Drive Clutch Lever and Auger Clutch Lever.....	15
Transmission Release Lever	16
FEATURES.....	17
Work Light	17
Snow Clearing Bar	17
BEFORE OPERATION	18
ARE YOU READY TO GET STARTED?	18
IS YOUR SNOWBLOWER READY TO GO?	18
Check the General Condition of the Snowblower.....	19
Check the Engine.....	19
CHECK YOUR WORK AREA	20
OPERATION	21
SNOWBLOWING PRECAUTIONS	21
STARTING THE ENGINE	21
STOPPING THE ENGINE	26
CLEANING SNOW	29
SNOW-CLEARING TIPS.....	32
REMOVING OBSTRUCTIONS	33
SERVICING YOUR SNOWBLOWER	34
THE IMPORTANCE OF MAINTENANCE	34
MAINTENANCE SAFETY.....	35
TOOL KIT	36
MAINTENANCE SCHEDULE	37
REFUELING	38
FUEL RECOMMENDATIONS	39

CONTENTS

SERVICING YOUR SNOWBLOWER (continued)	
ENGINE OIL LEVEL CHECK	40
ENGINE OIL CHANGE.....	41
ENGINE OIL RECOMMENDATIONS.....	42
HYDROSTATIC TRANSMISSION FLUID	43
SPARK PLUG SERVICE.....	45
TRACK ADJUSTMENT	47
TIRE INSPECTION	48
AUGER AND BLOWER INSPECTION	48
SHEAR BOLT REPLACEMENT PROCEDURE	49
SKID SHOES AND SCRAPER	50
STORAGE.....	52
STORAGE PREPARATION.....	52
Cleaning.....	52
Fuel.....	53
Engine Oil	56
Tires.....	56
STORAGE PRECAUTIONS	57
REMOVE FROM STORAGE	57
TRANSPORTING	58
BEFORE LOADING.....	58
LOADING.....	59
TAKING CARE OF UNEXPECTED PROBLEMS.....	60
ENGINE PROBLEMS.....	60
Engine Will Not Start	60
Engine Lacks Power.....	61
DRIVER PROBLEMS.....	62
Snowblower Does Not Move.....	62
SNOWBLOWER PROBLEMS	63
Snowblower Does Not Operate.....	63
TECHNICAL & CONSUMER INFORMATION	65
TECHNICAL INFORMATION	65
Serial Number Locations.....	65
Carburetor Modification for High Altitude Operation.....	66
Emission Control System Information.....	67
Air Index.....	69
Specifications	70
CONSUMER INFORMATION	73
Honda Publications.....	73
Customer Service Information.....	74
QUICK REFERENCE INFORMATION	Inside back cover

SNOWBLOWER SAFETY

IMPORTANT SAFETY INFORMATION

Honda snowblowers are designed to clear snow from driveways and walkways. Other uses can result in injury to the operator or damage to the snowblower and other property.

Most mishaps with snowblowers can be prevented if you follow all instructions in this manual and on the snowblower. The most common hazards, are discussed below, along with the best way to protect yourself and others.

Avoid Rotating Auger

The snowblower auger can cause serious cuts and even amputate fingers, hands, toes, or feet. Keep away from the auger whenever the engine is running. If you need to work around the snowblower to clear snow for any reason, always shut off the engine. If the snow discharge chute becomes clogged, stop the engine and disconnect the spark plug cap. Use the snow clearing bar or a wooden stick to remove the obstructions. Never put your hand into the snow discharge chute while the engine is running; serious personal injury could result.

Clear Operation Area

The snowblower can throw rocks and other objects with enough force to cause serious injury. Before operating the snowblower, carefully inspect the area and remove any visible stones, sticks, bones, nails, pieces of wire, and other loose objects. Never use the snowblower to clear snow from a gravel road or driveway, as rocks may be picked up and ejected. They may cause injury to bystanders.

SNOWBLOWER SAFETY

Keep Shields in Place

Guards and shields are designed to protect you from being hit by thrown objects and to keep you from touching hot engine parts and moving components. For your safety and the safety of others, keep all shields in place when the engine is running.

Adjust the snow discharge chute to avoid hitting the operator, bystanders, windows, and other objects with ejected snow. Stay clear of the snow discharge chute while the engine is running.

Children and pets must be kept away from the area of operation to avoid injury from flying debris and contact with the snowblower.

Refuel with Care

Gasoline is extremely flammable, and gasoline vapor can explode. Allow the engine to cool if the snowblower has been in operation. Refuel only outdoors in a well-ventilated area with the engine OFF. Never fill the fuel tank beyond the maximum fill mark. Never smoke near gasoline, and keep other flames and sparks away. Always store gasoline in an approved container.

Turn Engine OFF When Not Operating the Snowblower

If you need to leave the snowblower for any reason, even just to inspect the area ahead, always turn the engine off.

Operation on Slopes

To avoid overturning, be careful when changing the direction of the snowblower while operating it on a slope. Do not use the snowblower to remove snow from roofs. The snowblower may overturn on steep slopes if left unattended causing injury to the operator or bystanders.

Operating Conditions

Do not use the snowblower when visibility is poor. Under conditions of poor visibility, there is a greater risk of striking an obstacle or causing injury. Adjust the snow discharge chute to avoid hitting passing bystanders or vehicles. Stay clear of the snow discharge chute while the engine is running.

Operating Near Roads

Always watch for vehicle traffic when operating the snowblower near roads and driveways. Never operate the snowblower on public roads.

Operator Responsibility

Know how to stop the snowblower quickly in case of emergency. Understand the use of all snowblower controls.

Never permit anyone to operate the snowblower without proper instruction. Do not let children operate the snowblower. If people or pets suddenly appear in front of the snowblower while it is in operation, immediately release the auger and drive clutch levers to stop the snowblower and avoid possible injury from rotating auger blades.

While operating the snowblower, hold the handle firmly, and walk, don't run. Wear suitable winter boots that resist slipping.

SNOWBLOWER SAFETY

SAFETY LABEL LOCATIONS

These labels warn you of potential hazards that can cause serious injury. Read them carefully.

If a label comes off or becomes hard to read, contact your Honda snowblower dealer for a replacement.

⚠ WARNING

- USE EXTREME CARE TO AVOID INJURY.
- KEEP HANDS AND FEET AWAY FROM ALL ROTATING AND MOVING PARTS.
- DO NOT DIRECT DISCHARGE AT BYSTANDERS OR WINDOWS.
- TO PREVENT ACCIDENTAL START-UP, STOP THE ENGINE AND REMOVE THE SPARK PLUG CAP BEFORE MAKING REPAIRS, ADJUSTMENTS OR INSPECTIONS.
- USE A TROWEL OR LONG STICK TO CLEAR DEBRIS FROM THE DISCHARGE CHUTE.
- NEVER USE YOUR HAND TO STOP THE ENGINE IF YOU MUST LEAVE THE SNOW THROWER UNATTENDED.
- READ OWNER'S MANUAL BEFORE OPERATING.

⚠ DANGER



KEEP HANDS OUT OF DISCHARGE CHUTE WHILE ENGINE IS RUNNING.

⚠ WARNING

- GASOLINE IS FLAMMABLE.
- SHUT OFF ENGINE WHEN REFUELING.
- NEVER REFUEL INDOORS.
- DO NOT OVERFILL.

⚠ CAUTION

MUFFLER HOT

⚠ DANGER



KEEP HANDS AND FEET AWAY FROM AUGER WHILE ENGINE IS RUNNING.

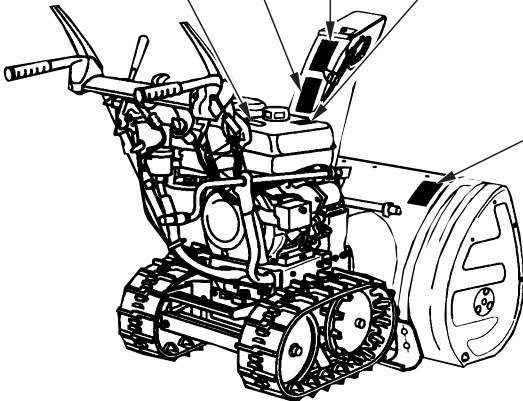

CONTROLS & FEATURES

COMPONENT & CONTROL LOCATIONS

Use the two illustrations on these pages to locate and identify the most frequently used controls.

Track type

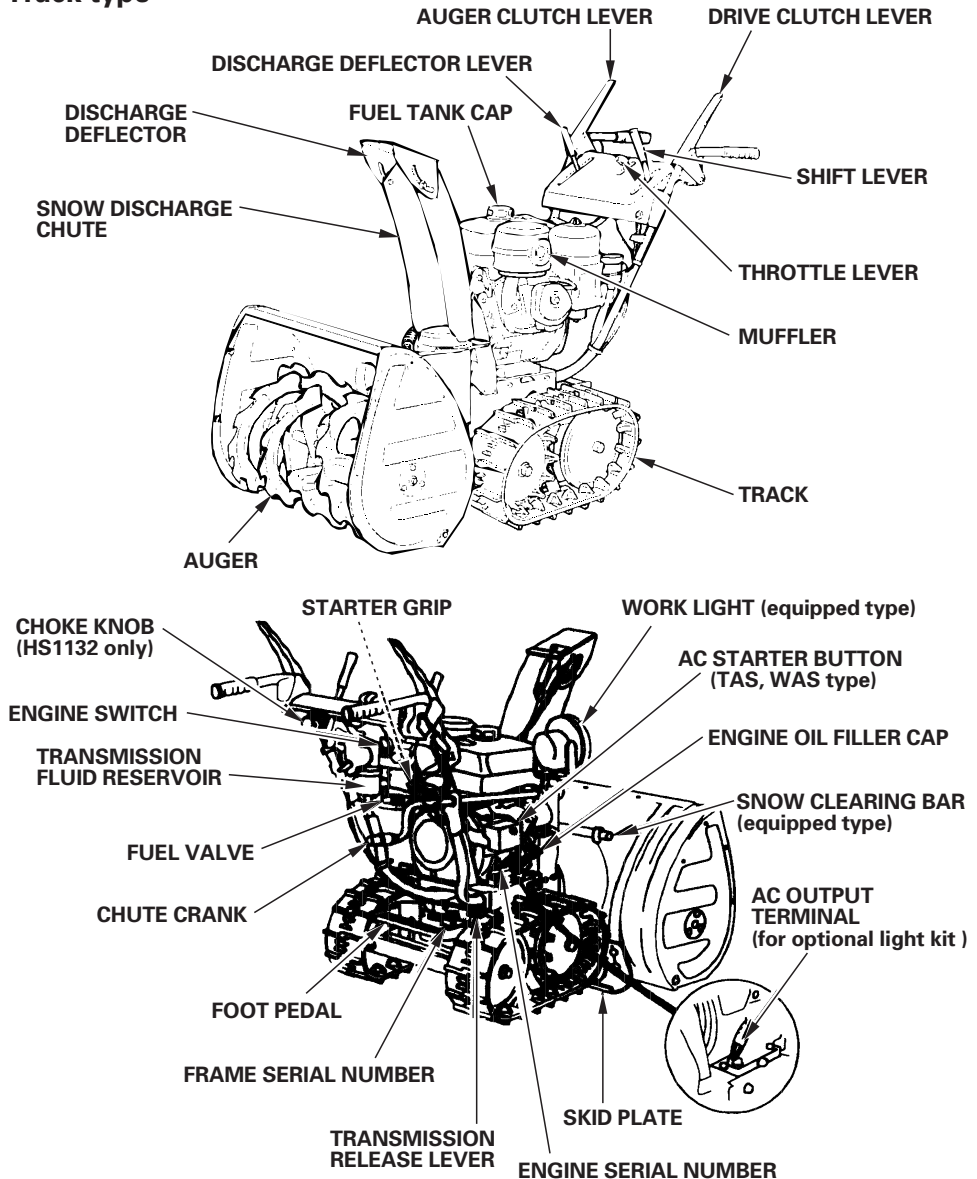

CONTROLS & FEATURES

Wheel type

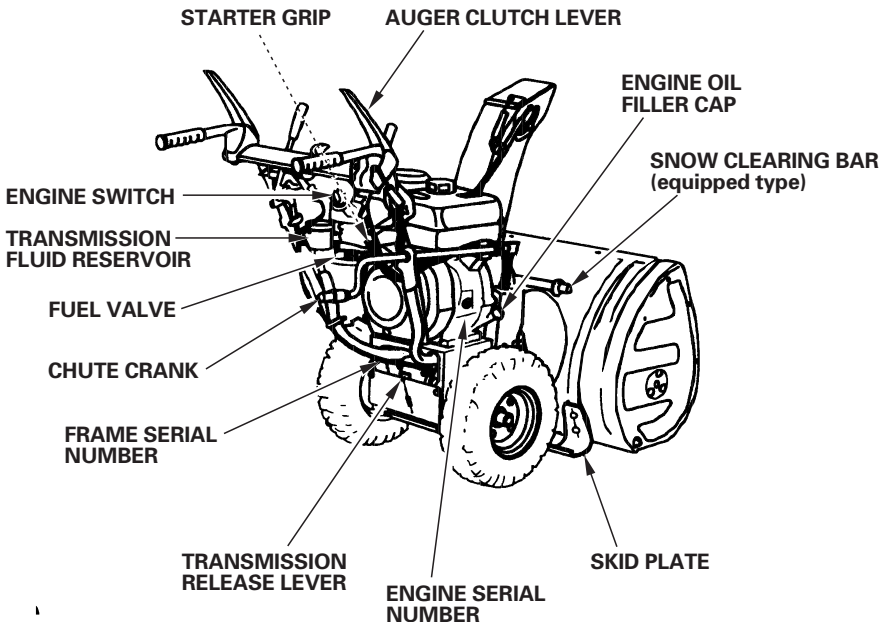
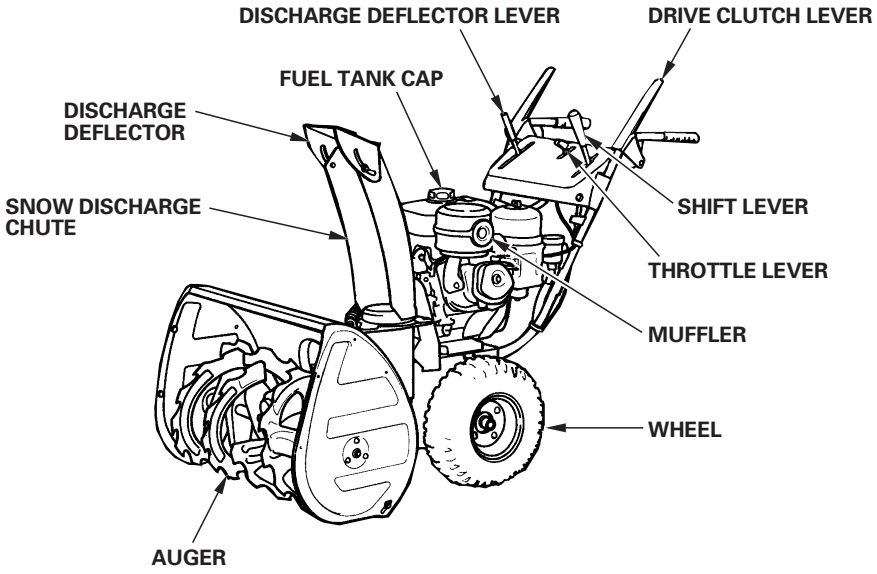

CONTROLS

Fuel Valve Lever

The fuel valve opens and closes the fuel line leading from the fuel tank to the carburetor. Make sure that the fuel valve is positioned exactly at either the ON or OFF position. When the snowblower is not in use, always leave the fuel valve in the OFF position to reduce the possibility of fuel leakage.

FUEL VALVE LEVER

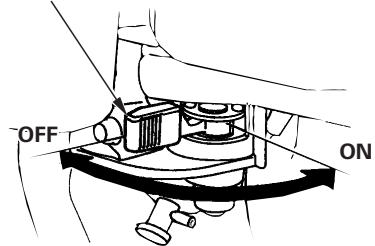

Engine Switch

The engine switch controls the ignition system. The key (if equipped) can only be inserted and removed when turned to OFF.

OFF — Stops the engine.

ON — Running position, and for starting with the recoil starter.

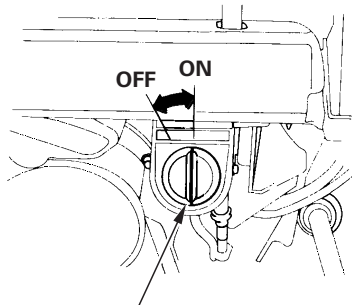

ENGINE SWITCH

Fuel Gauge (equipped type)

The fuel gauge indicates the amount of fuel in the tank. When the fuel gauge needle enters the "E" range, refill the tank as soon as possible.

FUEL GAUGE

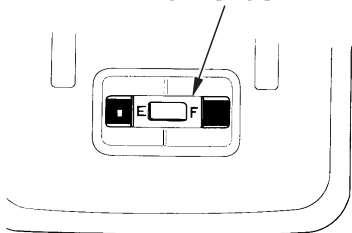

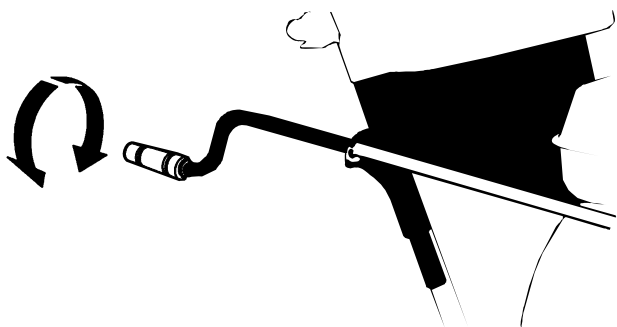

Choke Knob (HS1132 only)

The choke knob opens and closes the choke valve in the carburetor.

The CLOSED position enriches the fuel mixture for starting a cold engine.

The OPEN position provides the correct fuel mixture for operation after starting, and for restarting a warm engine.

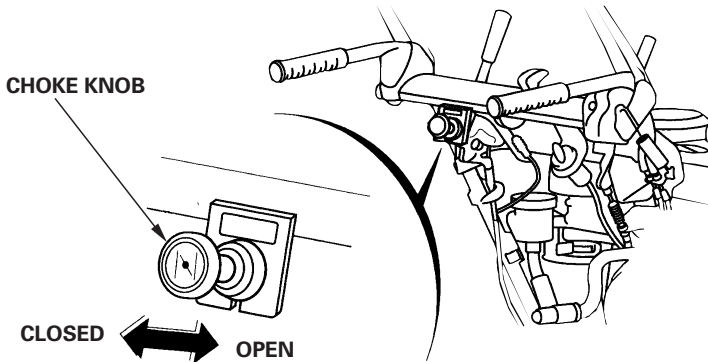

Shift Lever

The shift lever selects F (FORWARD), N (NEUTRAL), or R (REVERSE).

The shift lever also controls the transmission drive ratio; moving the lever farther from NEUTRAL increases drive speed. While clearing snow, use the shift lever to control drive speed, so you can leave the throttle lever in the FAST position for best snow-clearing performance.

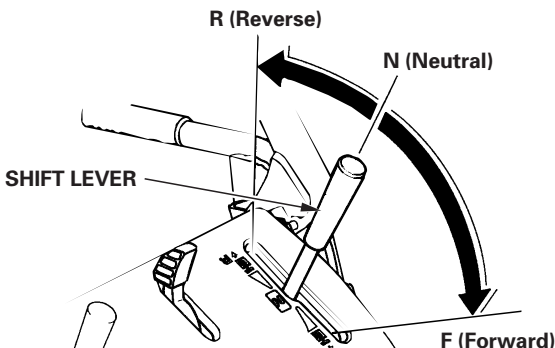

CONTROLS & FEATURES

Discharge Deflector Lever

The discharge deflector lever controls the snow discharge angle.

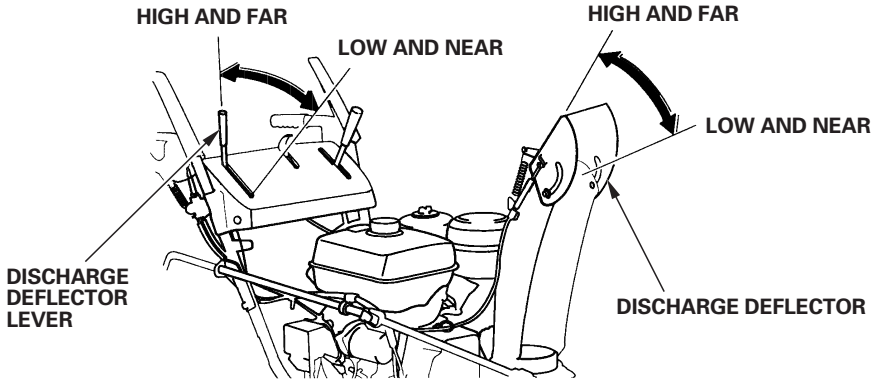

Foot Pedal (track type only)

Use the pedal for adjusting the height and angle of the machine in relation to the tracks.

Hold the handles and step on the pedal.

Raise or lower the machine to the desired position and release the pedal.

LOW — Smooth, ice-covered surfaces only.

MIDDLE — Normal use.

HIGH — Deep snow or for transporting the snowblower.

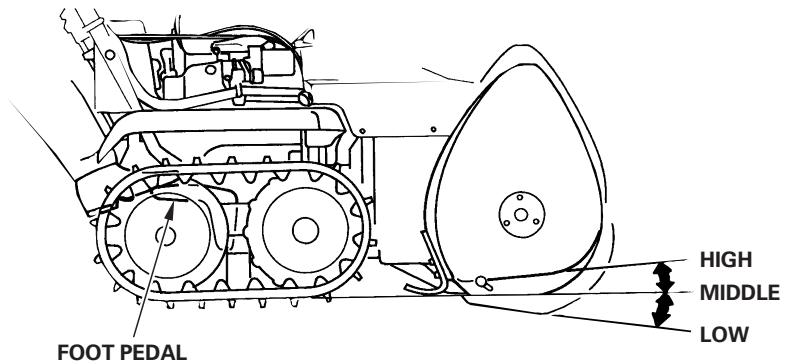

CONTROLS & FEATURES

Drive Clutch Lever and Auger Clutch Lever

Use these controls to engage the snow blowing mechanism and/or the drive mechanism.

AUGER CLUTCH LEVER
Squeeze to engage the snow blowing mechanism.

DRIVE CLUTCH LEVER
Squeeze to engage the drive transmission.

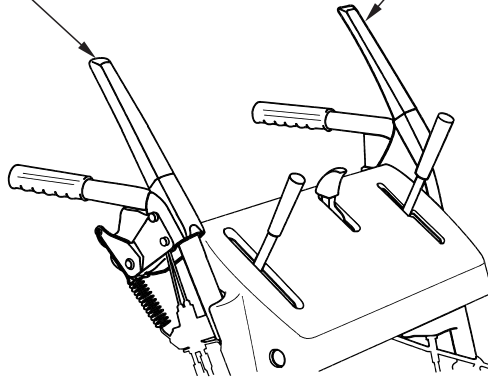

When both levers are squeezed, the drive clutch lever locks the auger clutch lever down. Releasing the drive clutch lever then unlocks and releases the auger clutch lever.

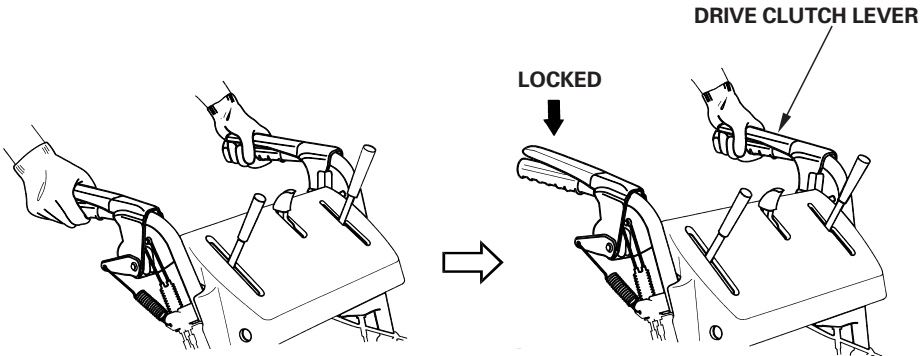

Both levers squeezed

The auger clutch lever remains locked down as long as one hand continues to squeeze the drive clutch lever.

CONTROLS & FEATURES

Transmission Release Lever

The transmission release lever has two positions, RELEASED and ENGAGED. Set the lever in the ENGAGED position for self-propelled operation. Set it in the RELEASED position when pushing the snowblower with the engine stopped.

NOTICE

Operating the transmission release lever while the engine is running can damage the transmission.

1. Stop the engine.
2. Set the shift lever in the "N" (Neutral) position.
3. Set the lever in the ENGAGED or RELEASED position.

NOTICE

Pushing or towing the snowblower with the transmission release control in the engaged position will damage the hydrostatic transmission.

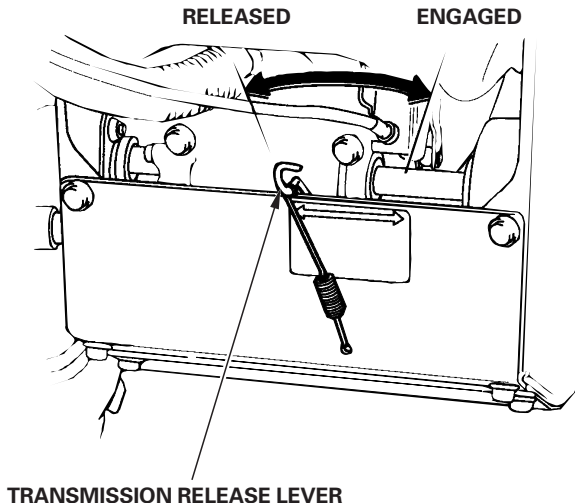

FEATURES

Work Light

HS1132	Standard
HS724, HS928	Optional Kit

The light comes ON while the engine is running, and it goes OFF when the engine stops. The light does not come ON when the engine switch is turned ON unless the engine is started. The light can be adjusted up or down.

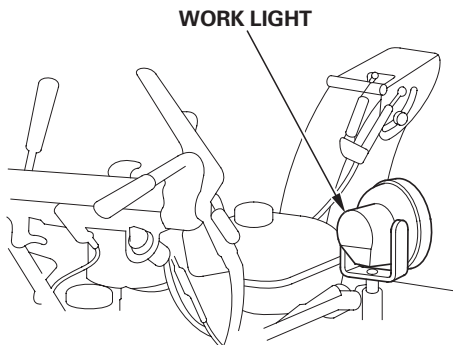

Snow Clearing Bar (equipped type)

If the snow discharge chute or snow blowing mechanism becomes restricted, stop the engine and use this bar to remove the obstruction.

After clearing the obstruction, wipe the bar clean, and store it in the holders.

Before removing the obstruction, be sure to stop the engine, and make sure that all rotating parts have come to a complete stop. Remove the spark plug cap from the spark plug.

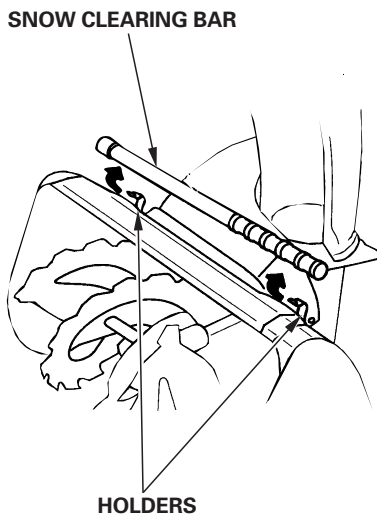

BEFORE OPERATION

ARE YOU READY TO GET STARTED?

Your safety is your responsibility. A little time spent in preparation will significantly reduce your risk of injury.

Knowledge

Read and understand this manual. Know what the controls do and how to operate them.

Familiarize yourself with the snowblower and its operation before you begin using it. Know how to quickly shut off the snowblower in case of an emergency.

IS YOUR SNOWBLOWER READY TO GO?

For your safety, and to maximize the service life of your equipment, it is very important to take a few moments before you operate the snowblower to check its condition. Be sure to take care of any problem you find, or have your servicing dealer correct it, before you operate the snowblower.

WARNING

Improperly maintaining this snowblower, or failing to correct a problem before operation, could cause a malfunction in which you could be seriously injured.

Always perform a pre-operation inspection before each operation, and correct any problem.

Before beginning your pre-operation checks, be sure the snowblower is on a level surface and the engine switch is in the OFF position.

Check the General Condition of the Snowblower:

- Look around and underneath the snowblower for signs of oil or gasoline leaks.
- Check the auger house and the discharge chute for accumulation of packed snow or ice. Clean the auger housing and discharge chute before starting the snowblower.
- Look for signs of damage.
- Check each control for proper operation.
- Check the auger and blower for loose or broken bolts. If broken, replace them with new ones (page 49).
- Check the skid shoes and scraper for wear. Replace them if necessary (page 50).
- Check that all nuts, bolts, screws are tightened.

Check the Engine

- Check the oil level (page 40).
- Check the fuel level (page 38). Starting with a full tank will help to eliminate or reduce operating interruptions for refueling.
- Check the hydrostatic fluid level in the reservoir (page 43). Use only Honda Hydrostatic Fluid.

BEFORE OPERATION

CHECK YOUR WORK AREA

For your safety and the safety of others, always inspect the area before operating the snowblower.

Objects

Anything which can be picked up by the augers and thrown is a potential hazard to you and others. Look for things like stones, sticks, bones, nails, and wire, and remove them from the work area.

People and Pets

People and animals near the work area can move into your snowblowers path or into a position where they could be struck by thrown objects. Clear the area of people, especially children and pets. Their safety is your responsibility.

Work Area

Check the condition of the snow. Adjust your snowblower ground speed (not engine speed) and snowblowing swath accordingly.

Check the skid shoes for proper adjustment. Adjust the skid shoes to obtain the auger ground clearance for the type of surface the snowblower will be operated over (page 51).

OPERATION

SNOWBLOWING PRECAUTIONS

Before operating the snowblower for the first time, please review both the *SNOWBLOWER SAFETY* chapter (page 5) and the *BEFORE OPERATION* chapter (page 18).

Even if you have operated other snowblowers, take time to become familiar with how this snowblower works, and practice in a safe area until you build up your skills.

Never tamper with or alter any of the controls or safety devices on the snowblower.

For your safety, do not start or operate the engine in an enclosed area such as a garage. Your snowblower’s exhaust contains poisonous carbon monoxide gas that can collect rapidly in an enclosed area and cause illness or death.

⚠ WARNING

Exhaust contains poisonous carbon monoxide gas that can build up to dangerous levels in closed areas. Breathing carbon monoxide can cause unconsciousness or death.

Never run the generator in a closed, or even partly closed area where people may be present.

STARTING THE ENGINE

1. Move the shift lever to “N” (Neutral) position.

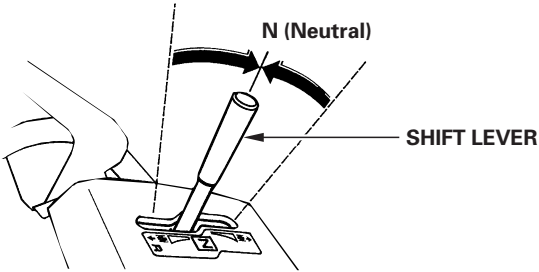

OPERATION

2. Set the transmission release lever in the ENGAGED position (page 16).

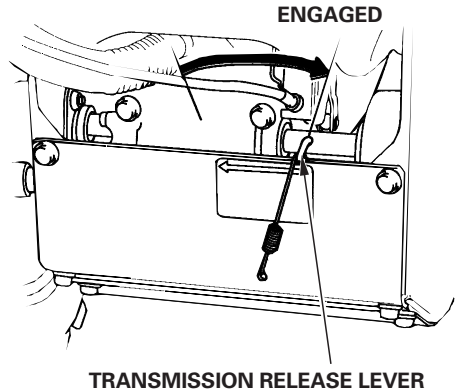

3. Turn the fuel valve to the ON position. Be sure that the drain knob is tightened securely.

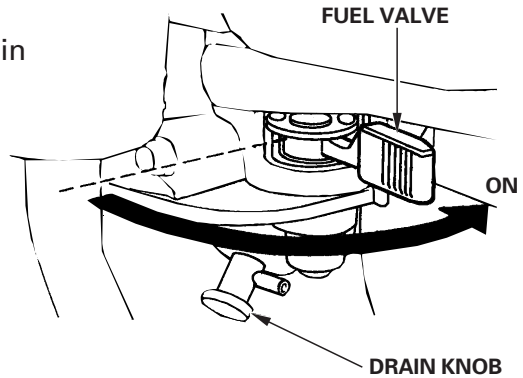

4. In cold weather and when the engine is cold, follow the procedures below.

HS724/HS928:

Move the throttle lever to the CHOKE position.

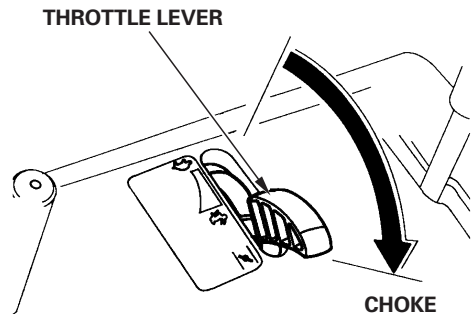

HS1132:

Pull the choke knob to the CLOSED position and move the throttle lever to the FAST position.

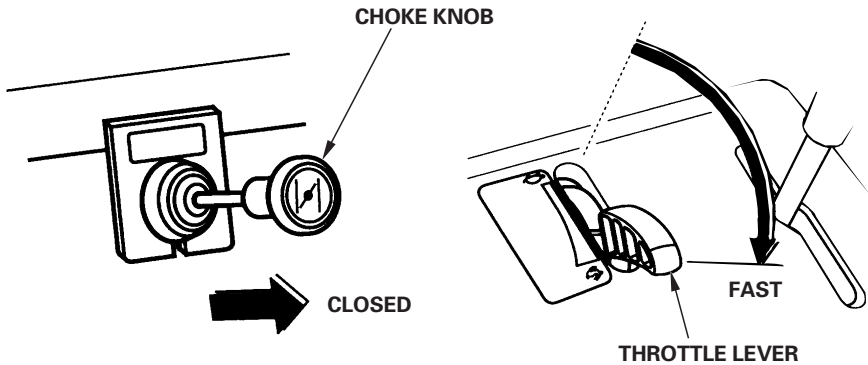

5. Start the engine.

Electric-start Models (TAS, WAS type):

a. Connect your power cord to the switch box and the male end of the power cord to a properly grounded 120 Volt ac outlet.

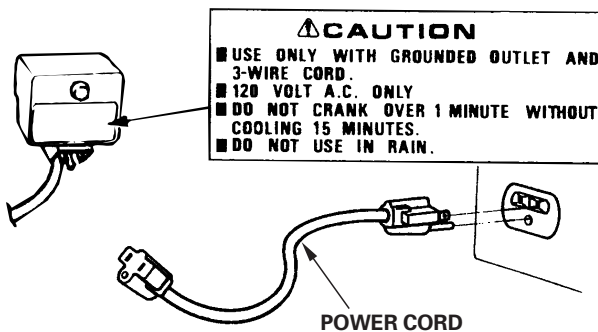

To minimize the possibility of potentially dangerous electrical shocks, always use a 3-conductor power cord with a power rating of no less than 15 amps. Also, be sure that the outlet you are using is properly grounded.

Do not connect and disconnect the power cord with wet hands.

Be sure to hold the plug when disconnecting the power cord from the electrical outlet or switch box. Do not disconnect by pulling on the power cord.

OPERATION

- b. Turn the engine switch to the ON position.

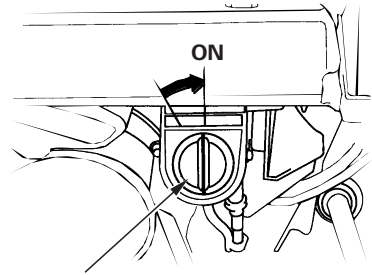

ENGINE SWITCH

- c. Push the starter button until the engine starts. After the engine starts, disconnect the power cord from the electrical outlet, and then from the switch box.

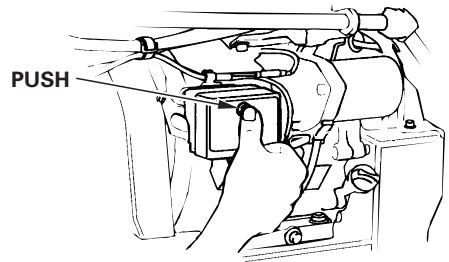

NOTICE

Do not operate the starter for more than 1 minute. If the engine fails to start, release the button and allow the starter to cool for 15 minutes before operating it again.

Manual Starting only

- a. Turn the engine switch to the ON position.
- b. Pull the starter grip lightly until you feel resistance, then pull briskly in the direction of the arrow as shown.
- c. Return the starter grip gently to the engine.

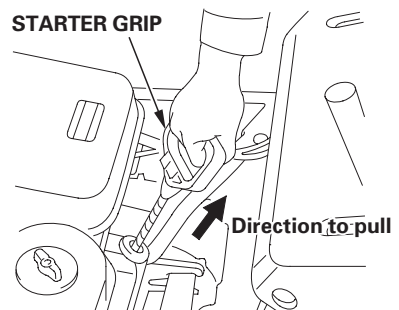

NOTICE

- *Do not allow the starter grip to snap back against the engine. Return it gently to prevent damage to the starter.*
- *Do not pull the starter grip while the engine is running. The starter could be damaged.*

6. Let the engine warm up for several minutes.

HS724/HS928:

If the throttle lever has been moved to the CHOKE position, gradually move the throttle lever to the SLOW position as the engine warms up.

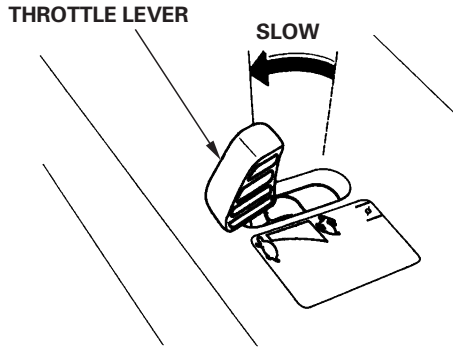

HS1132:

If the choke knob has been pulled to the CLOSED position to start the engine, gradually push it to the OPEN position as the engine warms up. Move the throttle lever to the SLOW position.

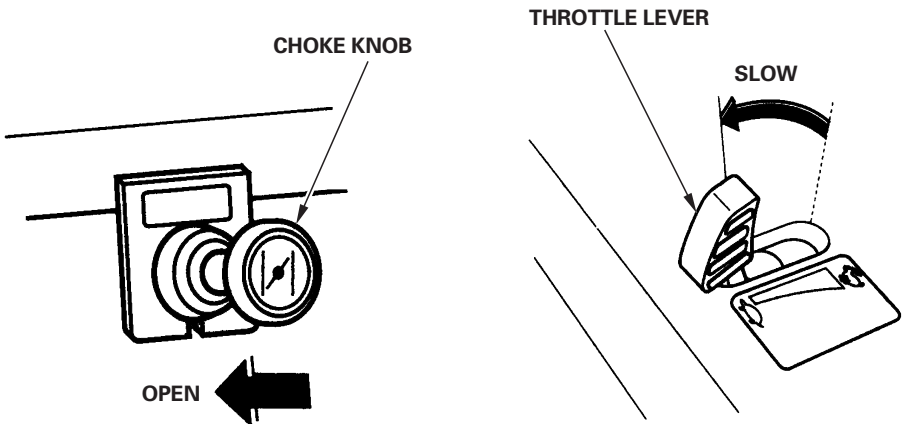

OPERATION

7. While warming the engine up, also warm the transmission as follows:

a. Check that the shift lever is in the "N" (Neutral) position.

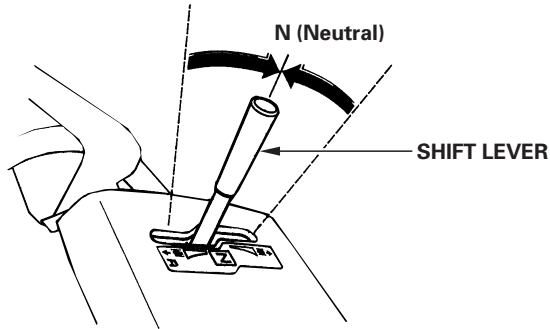

b. Squeeze the drive clutch lever for about 30 seconds to warm up the transmission fluid.

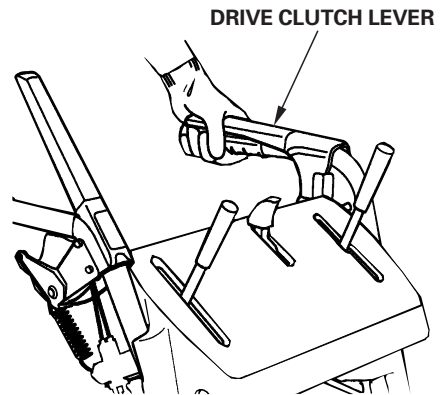

STOPPING THE ENGINE

To stop the engine in an emergency, simply turn the engine switch to the OFF position. Under normal conditions, use the following procedure.

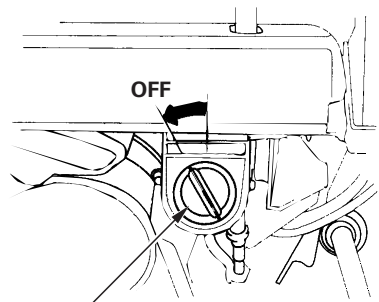

ENGINE SWITCH

1. Release the auger and drive clutch levers. The drive and snow blowing mechanism will stop operation.

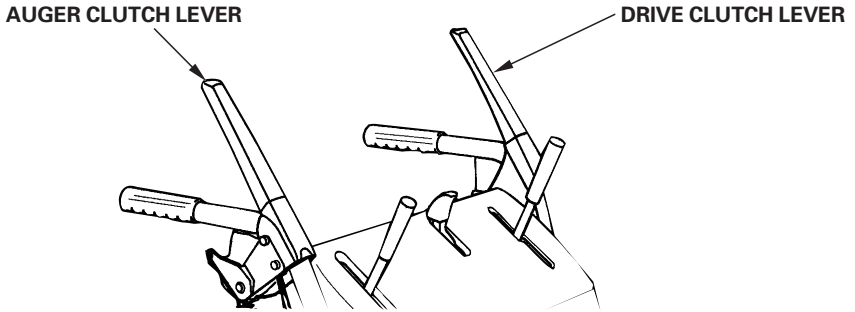

2. Move the shift lever to "N" (Neutral) position.

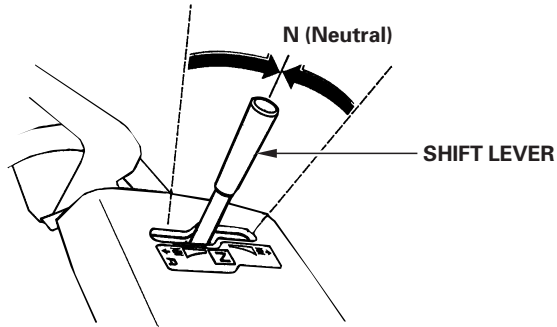

3. Turn the throttle lever to the SLOW position.

HS724/HS928:

THROTTLE LEVER

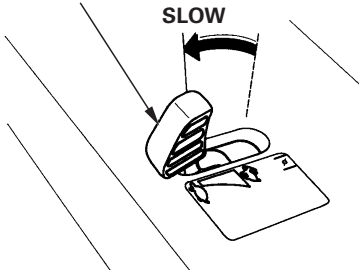

HS1132:

THROTTLE LEVER

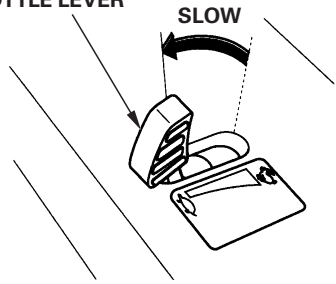

OPERATION

4. Turn the engine switch to the OFF position.

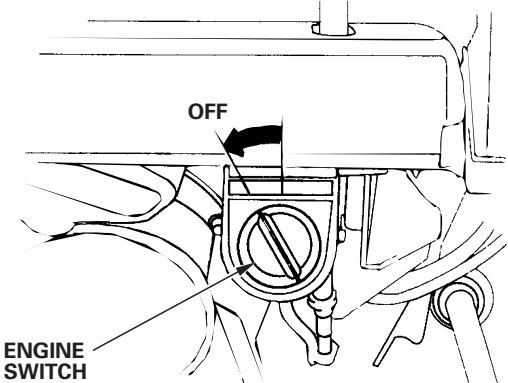

5. Turn the fuel valve to the OFF position.

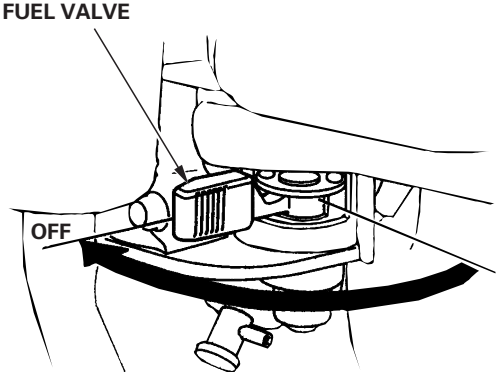

CLEARING SNOW

1. Move the throttle lever to the FAST position for normal operation.
2. Release the auger clutch lever, and move the shift lever to select the desired drive speed.

Low speed is recommended for removing deep or hard-packed snow.

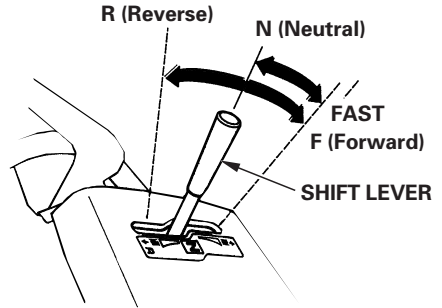

3. Set the foot pedal to the correct position (page 14 , track type only).
4. Adjust the throwing direction by using the chute crank and the discharge deflector lever (page 12 and 14).
5. Squeeze the auger clutch lever.
The machine will clear snow when you squeeze the auger clutch lever.

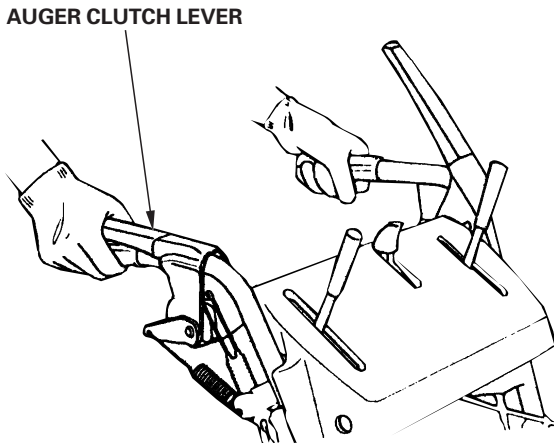

OPERATION

6. Squeeze the drive clutch lever to self-propel the snowblower.

If the transmission release lever (page 22) is in the ENGAGED position, and the shift lever (page 29) is in the FORWARD (F) position, the hydrostatic drive will propel the snowblower forward when you squeeze the drive clutch lever.

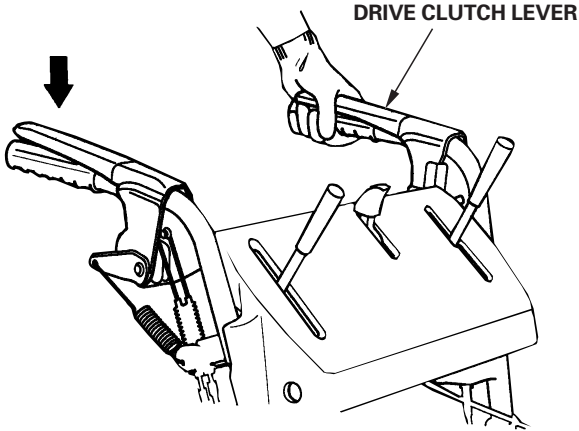

When both levers are squeezed, the drive clutch lever locks the auger clutch lever down. This frees your right hand to operate the other snowblower controls. Releasing the drive clutch lever unlocks and releases the auger clutch lever.

To move from one place to another, or to change direction, use the drive clutch lever only. Release both the drive clutch lever and auger clutch lever, and then squeeze the drive clutch lever.

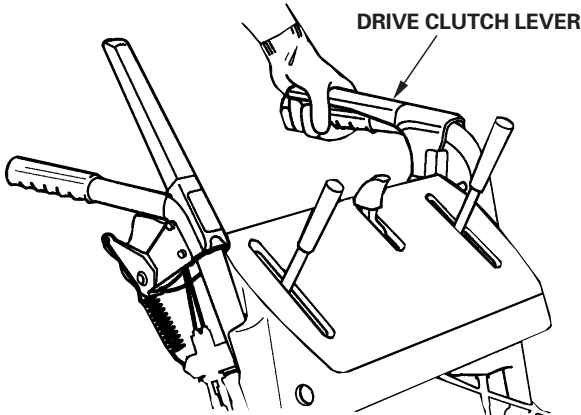

7. Release the clutch levers to stop clearing or moving.

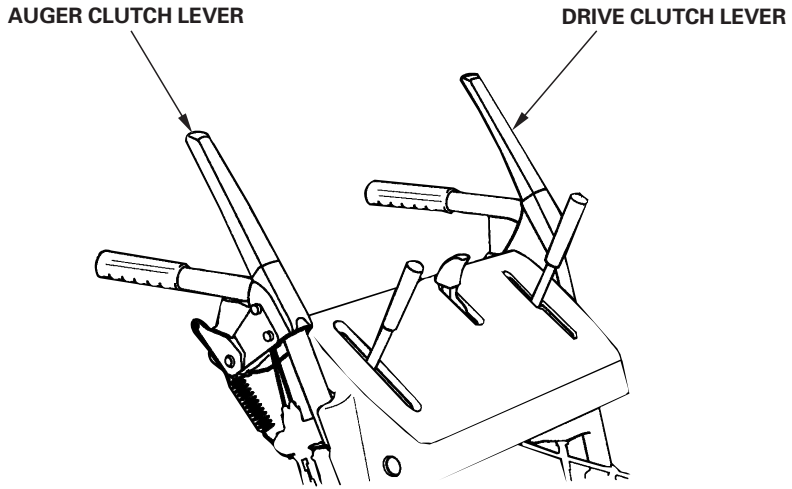

OPERATION

SNOW-CLEARING TIPS

For best efficiency, clear snow before it melts, refreezes and hardens. Do not reduce engine speed while clearing snow.

Operating tips for clearing hard or deep snow:

- Reduce forward speed. If that is not sufficient, use the shift lever to clear snow with a back and forth motion.
- Clear a narrower swath. Make several passes with the auger overlapping the cleared areas.
- If the snow is deeper than the height of the auger, remove it in several steps, as shown below, or install the drift-breaker kit (optional part) that is available from authorized Honda snowblower dealers.

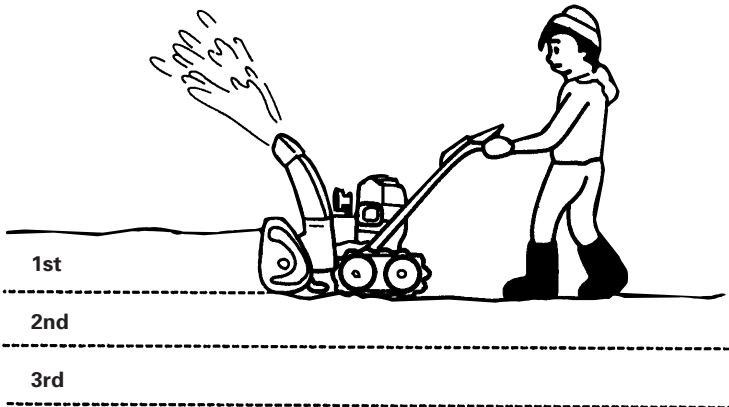

REMOVING OBSTRUCTIONS

If the snow discharge chute or snow blowing mechanism becomes restricted, review snow clearing information (page 32) to reduce the possibility of reoccurring obstructions.

1. Before removing the obstruction, be sure to stop the engine, and make sure that all rotating parts have come to a complete stop. Remove the spark plug cap from the spark plug.
2. Remove the snow clearing bar (if equipped), or use a wooden stick to clear the obstruction.
3. After unclogging, wipe the bar clean, and secure it in the holders.

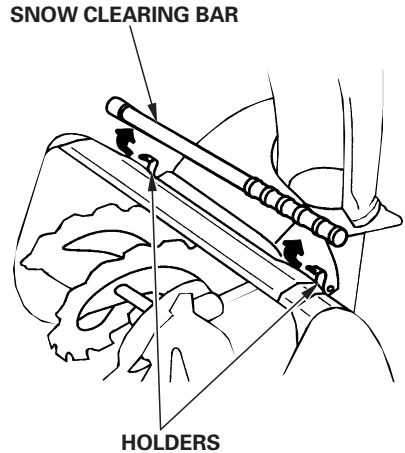

SERVICING YOUR SNOWBLOWER

THE IMPORTANCE OF MAINTENANCE

Good maintenance is essential for safe, economical, and trouble-free operation. It will also help reduce air pollution.

To help you properly care for your snowblower, the following pages include a maintenance schedule, routine inspection procedures, and simple maintenance procedures using basic hand tools. Other service tasks that are more difficult, or require special tools, are best handled by professionals and are normally performed by a Honda technician or other qualified mechanic.

The maintenance schedule applies to normal operating conditions. If you operate your snowblower under unusual conditions, consult your servicing dealer for recommendations applicable to your individual needs and use. Remember that your servicing dealer knows your snowblower best and is fully equipped to maintain and repair it.

WARNING

Improper maintenance, or failure to correct a problem before operation, can cause a malfunction in which you can be seriously hurt or killed.

Always follow the inspection and maintenance recommendations and schedules in this owner's manual.

To ensure the best quality and reliability, use only new, Honda Genuine parts or their equivalents for repair or replacement.

Maintenance, replacement, or repair of the emission control devices and systems may be performed by any engine repair establishment or individual, using parts that are "certified" to EPA standards.

SERVICING YOUR SNOWBLOWER

MAINTENANCE SAFETY

Some of the most important safety precautions follow. However, we cannot warn you of every conceivable hazard that can arise in performing maintenance. Only you can decide whether or not you should perform a given task.

WARNING

Failure to properly follow maintenance instructions and precautions can cause you to be seriously hurt or killed.

Always follow the procedures and precautions in the owner's manual.

Safety Precautions

- Make sure the engine is off before you begin any maintenance or repairs. This will eliminate several potential hazards:
 - **Carbon monoxide poisoning from engine exhaust.**
Operate outside, away from open windows or doors.
 - **Burns from hot parts.**
Let the engine and exhaust system cool before touching.
 - **Injury from moving parts.**
Do not run the engine unless instructed to do so.
- Read the instructions before you begin, and make sure you have the tools and skills required.
- To reduce the possibility of fire or explosion, be careful when working around gasoline. Use only a nonflammable solvent, not gasoline, to clean parts. Keep cigarettes, sparks, and flames away from all fuel-related parts.

SERVICING YOUR SNOWBLOWER

TOOL KIT

The tools necessary for performing some of the periodic maintenance, simple adjustments and repairs are supplied in the tool kit.

Spare shear bolts and nuts are also located in the tool kit.

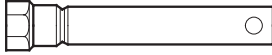

SPARK PLUG WRENCH



WRENCH HANDLE

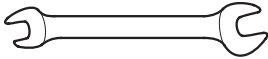

10 × 14 mm WRENCH

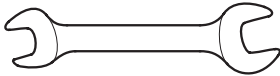

**12 × 14 mm WRENCH (HS724/HS928)
12 × 17 mm WRENCH (HS1132)**

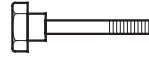

BLOWER SHEAR BOLT



6 mm SELF LOCK NUT (4)



AUGER SHEAR BOLT (3)

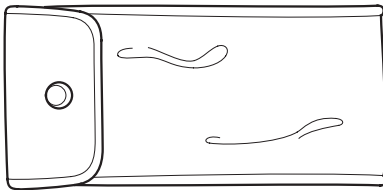

TOOL BAG

SERVICING YOUR SNOWBLOWER

MAINTENANCE SCHEDULE

REGULAR SERVICE PERIOD (3) ITEM Performed at every indicated month or operating hour interval, whichever comes first.	Each use	First month or 20 Hrs.	EVERY YEAR		Every 5 years	Page
			Before operation	Before storage		
Engine oil	Check level	○				40
	Change		○ (1)			41
HST oil	Check level	○				43
Spark plug	Check-adjust		○ (1)			45
	Replace				○ (250 Hrs.)	
Auger skid shoes and scraper	Check-adjust	○	○ (1)			50
Track	Adjust		○ (1)			47
Wheel	Check	○		○		48
Auger and blower shear bolts	Check	○				49
Bolts, nuts, fasteners	Check	○				19
Fuel sediment cup	Clean			○		55
Anti corrosion oil	Apply oil			○		52
Chute guide cable	Check-adjust		○ (1) (2)			—
Fuel tank and carburetor	Drain			○		55
Auger clutch cable	Check-adjust		○ (1) (2)			—
Drive clutch cable	Check-adjust		○ (1) (2)			—
Idle speed	Check-adjust		○ (2)			—
Throttle/Choke cable	Check-adjust		○ (1) (2)			—
Drive, Auger belt	Check-adjust		○ (1) (2) (4)			—
Transmission	Grease		○ (2)			—
Fuel tank and filter	Clean				○ (2)	—
Fuel tube	Check	Every 2 years (Replace if necessary)(2)				—
Valve clearance	Check-adjust		○ (2)			—
Combustion chamber	Clean	After every 250 Hrs. (2)				—

- (1) These parts may require more frequent inspection and replacement under heavy use.
- (2) These items should be serviced by your Honda servicing dealer, unless you have the proper tools and are mechanically proficient. Refer to the Honda Shop Manual for service procedures.
- (3) For professional commercial use, log hours of operation to determine proper maintenance intervals.
- (4) Check the belt for wear or damage. Replace the belt with a new one if it is worn or damaged.

Failure to follow this maintenance schedule could result in non-warrantable failures.

SERVICING YOUR SNOWBLOWER

REFUELING

With the engine stopped, remove the fuel tank cap and check the fuel level. Refill the tank if the fuel level is low. Do not fill above the base of the filler neck.

⚠ WARNING

Gasoline is highly flammable and explosive. You can be burned or seriously injured when handling fuel.

- Stop the engine and keep heat, sparks, and flames away.
- Handle fuel only outdoors.
- Wipe up spills immediately.

Refuel in a well-ventilated area before starting the engine. If the engine has been running, allow it to cool. Refuel carefully to avoid spilling fuel. Do not fill the fuel tank completely. Fill tank to approximately 1.4 inch (35 mm) below the top of the fuel tank to allow for fuel expansion. It may be necessary to lower the fuel level depending on operating conditions. After refueling, tighten the fuel tank cap securely.

Never refuel the snowblower inside a building where gasoline fumes may reach flames or sparks. Keep gasoline away from appliance pilot lights, barbecues, electric appliances, power tools, etc.

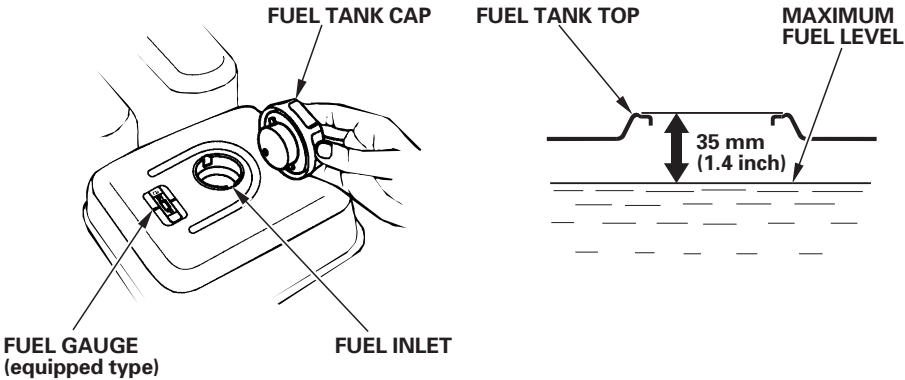

SERVICING YOUR SNOWBLOWER

Spilled fuel is not only a fire hazard, it causes environmental damage. Wipe up spills immediately.

NOTICE

Fuel can damage paint and plastic. Be careful not to spill fuel when filling your fuel tank. Damage caused by spilled fuel is not covered under warranty.

FUEL RECOMMENDATIONS

These engines are certified to operate on unleaded gasoline with a pump octane rating of 86 or higher.

You may use regular unleaded gasoline containing no more than 10% Ethanol (E10) or 5% Methanol by volume. In addition, Methanol must contain cosolvents and corrosion inhibitors.

Use of fuels with content of Ethanol or Methanol greater than shown above may cause starting and/or performance problems. It may also damage metal, rubber, and plastic parts of the fuel system.

Engine damage or performance problems that result from using a fuel with percentages of Ethanol or Methanol greater than shown above are not covered under warranty.

Never use stale or contaminated gasoline or an oil/gasoline mixture. Avoid getting dirt or water in the fuel tank.

SERVICING YOUR SNOWBLOWER

ENGINE OIL LEVEL CHECK

Check the engine oil level with the engine stopped and in a level position.

1. Remove the oil filler cap/dipstick and wipe it clean.
2. Insert and remove the dipstick without screwing it into the filler neck. Check the oil level shown on the dipstick.
3. If the oil level is low, fill to the edge of the oil filler hole (HS928, HS 1132), or upper limit mark (HS724) with the recommended oil (page 42).
4. Reinstall the oil filler cap/dipstick.

HS928/HS1132:

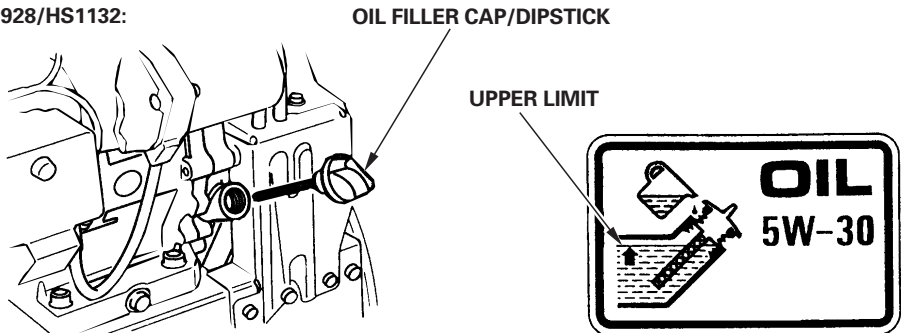

HS724:

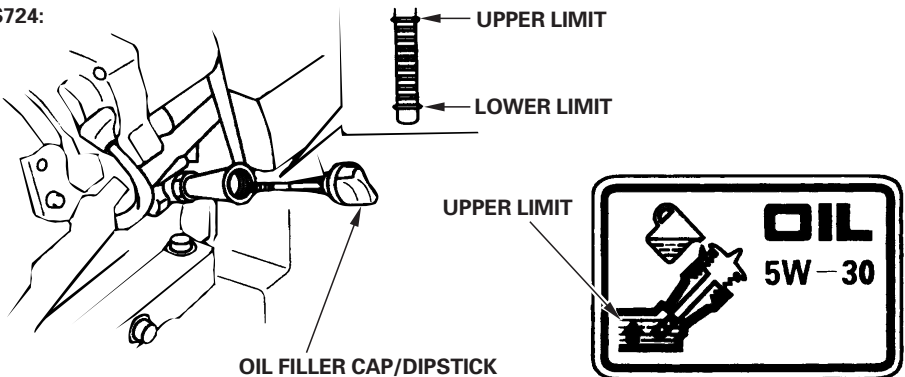

NOTICE

Running the engine with a low oil level can cause engine damage. This type of damage is not covered by the Distributor's Limited Warranty.

SERVICING YOUR SNOWBLOWER

ENGINE OIL CHANGE

Drain the oil while the engine is still warm to assure rapid and complete draining.

1. Place the snowblower on a level surface. If your snowblower is the track type, use the foot pedal (page 14) to raise the engine.
2. Place a suitable container below the engine to catch the used oil, then remove the oil filler cap/dipstick and the drain plug.

HS1132 ONLY:

To avoid loosening the drain plug extension, hold it with a 17 mm wrench while loosening the drain plug with a 10 mm wrench.

HS724/HS928:

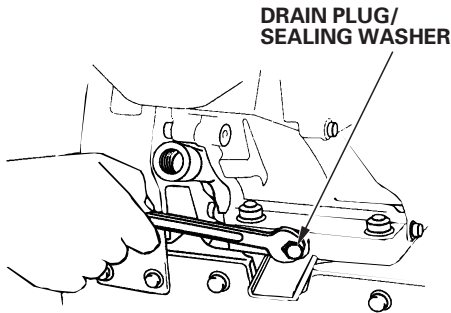

HS1132:

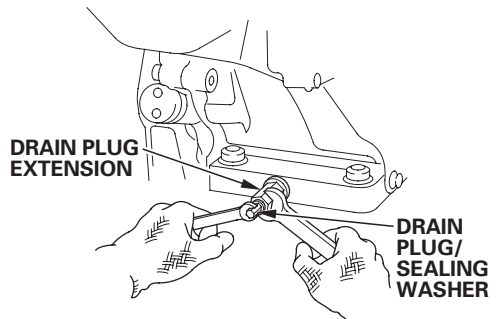

3. Allow the used oil to drain completely into an approved container, then reinstall the drain plug with a new sealing washer, and tighten it securely.

NOTICE

Improper disposal of engine oil can be harmful to the environment. If you change your own oil, please dispose of used motor oil properly. Put it in a sealed container, and take it to a recycling center. Do not throw it in the trash, pour it on the ground, or pour it down a drain.

SERVICING YOUR SNOWBLOWER

4. If the oil level is low, fill to the edge of the oil filler hole (HS928, HS 1132), or upper limit mark (HS724) with the recommended oil (page 42).

HS928/HS1132:
UPPER LIMIT



HS724:
UPPER LIMIT

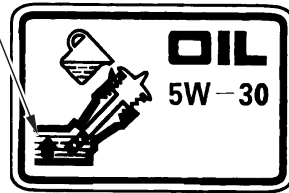

NOTICE

Running the engine with a low oil level can cause engine damage. This type of damage is not covered by the Distributor's Limited Warranty.

5. Screw in the oil filler cap/dipstick securely.

ENGINE OIL RECOMMENDATIONS

Oil is a major factor affecting performance and service life. Use a 4-stroke automotive detergent oil.

SAE 5W-30 is recommended for general use.

The SAE oil viscosity and service classification are on the API label on the oil container. Honda recommends that you use API SERVICE category SJ or later (or equivalent) oil.

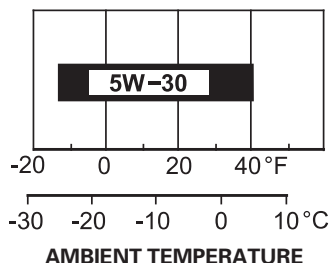

SERVICING YOUR SNOWBLOWER

HYDROSTATIC TRANSMISSION FLUID

Check the hydrostatic fluid level in the reservoir.

Hydrostatic fluid expands and contracts with changes in temperature. The UPPER and LOWER limit marks on the reservoir are calibrated for room temperature fluid.

It is normal for the fluid level to rise above the UPPER level mark when snowblower operation warms the transmission.

When checking the level of cold fluid, below room temperature, refer to the temperature chart for appropriate fluid levels (page 44).

At temperatures below -4°F (-20°C), fluid may not be visible in the reservoir before operation, but should rise into the reservoir when the transmission warms up.

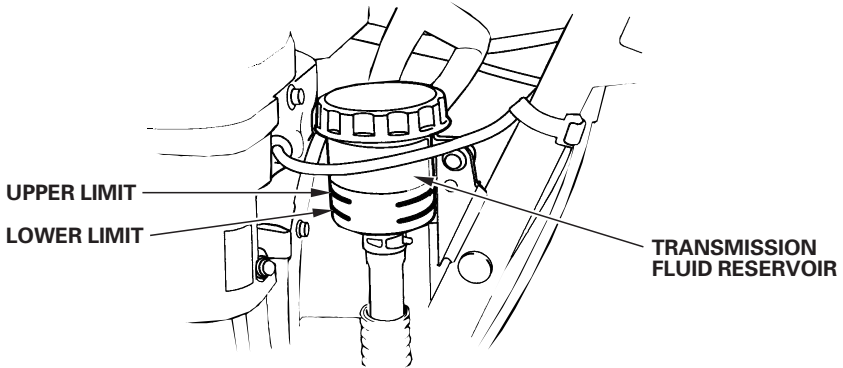

SERVICING YOUR SNOWBLOWER

If the fluid level is low, add Honda Hydrostatic Fluid.

NOTICE

The use of other hydrostatic fluids will reduce transmission performance and may damage the transmission. Use only Honda Hydrostatic Fluid.

1. Unscrew the reservoir cap and remove the seal. Be careful to prevent dirt, water, or snow from entering the reservoir.
2. Add Honda Hydrostatic Fluid to bring the fluid level to the UPPER limit mark at room temperature, or to the appropriate level shown in the temperature chart below. Do not overfill.
3. Reinstall the seal, and tighten the cap securely.

Temp	Fluid level
68°F (20°C)	Between upper and lower limit marks (approx. 0.20 in (5 mm) above lower limit marks)
50°F (10°C)	Slightly above lower limit mark (approx. 0.08 in (2 mm) above lower limit mark)
32°F (0°C)	Slightly below lower limit mark (approx. 0.04 in (1 mm) below lower limit mark)
14°F (-10°C)	Between lower limit mark and bottom of reservoir (approx. 0.16 in (4 mm) below lower limit mark)

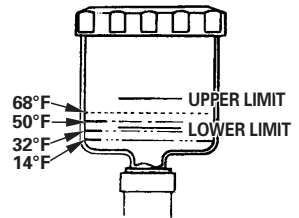

SERVICING YOUR SNOWBLOWER

SPARK PLUG SERVICE

Recommended spark plug: BPR5ES (NGK)
W16EPR-U (DENSO)

NOTICE

- *Use only the recommended spark plugs or equivalent. Spark plugs which have an improper heat range may cause engine damage.*

To ensure proper engine operation, the spark plug must be properly gapped and free of deposits. If the engine has been running, the muffler will be very hot. Be careful not to touch the muffler.

1. Remove the spark plug cap.
2. Clean any dirt from around the spark plug base.
3. Use the spark plug wrench supplied in the tool kit to remove the spark plug.
4. Inspect the spark plug. Replace it if the electrodes are worn or if the insulator is cracked, chipped, or fouled.

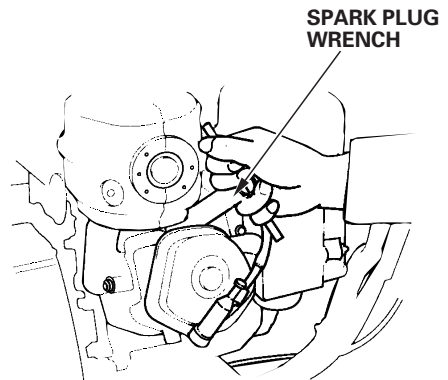

SERVICING YOUR SNOWBLOWER

5. Measure the plug gap with a wire-type feeler gauge. Correct as necessary by carefully bending the side electrode.

The gap should be:
0.028–0.031 in (0.7–0.8 mm)

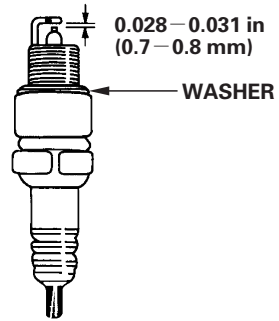

6. Make sure that the spark plug washer is in good condition, and thread the spark plug in by hand to prevent cross-threading.

7. After the spark plug is seated, tighten with a spark plug wrench to compress the washer.

If installing a new spark plug, tighten 1/2 turn after the spark plug seats to compress the washer. If reinstalling a used spark plug, tighten 1/8 to 1/4 turn after the spark plug seats.

NOTICE

- *The spark plug must be securely tightened. An improperly tightened spark plug can become very hot and may damage the engine.*

SERVICING YOUR SNOWBLOWER

TRACK ADJUSTMENT

Make sure the tracks are clean and dry before adjustment. The tracks cannot be correctly adjusted if clogged with snow or debris, or coated with ice.

With the snowblower resting on its tracks, check track deflection by pressing down midway between the wheels with a force of 33 lbf (15 kgf).

When correctly adjusted, track deflection should be:
1-1/16 – 1-5/16 in (27 – 33 mm)

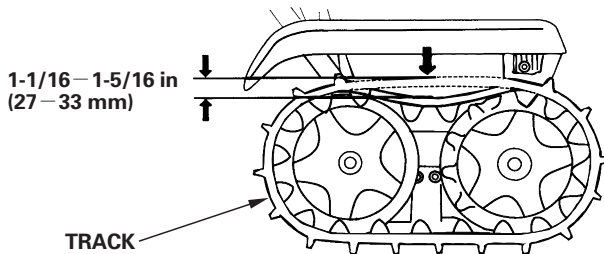

Adjusting Procedure

1. Loosen the left and right tension bolt lock nuts at the rear axle, and turn the adjusting nuts to correctly tension both tracks.
2. After adjustment, tighten the lock nuts securely.

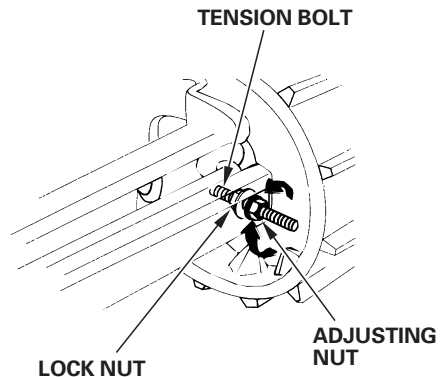

SERVICING YOUR SNOWBLOWER

TIRE INSPECTION

- Check the side wall and tread surface of each tire for cracks, damage, or excessive wear.
- Check the tire pressure
Tire pressure:
8.5 psi (59 kPa , 0.6 kgf/cm²)

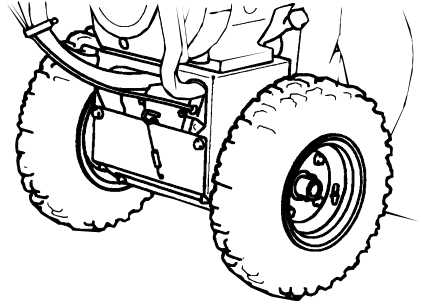

NOTICE

Excessive inflation pressure can damage the tires. Do not inflate the tires beyond the recommended pressure.

AUGER AND BLOWER INSPECTION

Check the auger, auger housing, blower and shear bolts for signs of damage or other faults. If any of the shear bolts are broken, replace them with the ones furnished with the snowblower. Additional shear bolts and nuts are available from authorized Honda snowblower dealers.

NOTICE

Shear bolts are designed to break under force that would otherwise damage auger and blower parts. Do not replace shear bolts with ordinary hardware bolts.

SERVICING YOUR SNOWBLOWER

SHEAR BOLT REPLACEMENT PROCEDURE

1. Place the snowblower on a firm, level surface.
2. Turn the engine switch OFF, and remove the cap from the spark plug.
3. Clean the auger and blower of snow, ice or any other foreign particles.
4. Check the entire snow clearing mechanism.
5. Replace any broken shear bolts. Tighten securely.

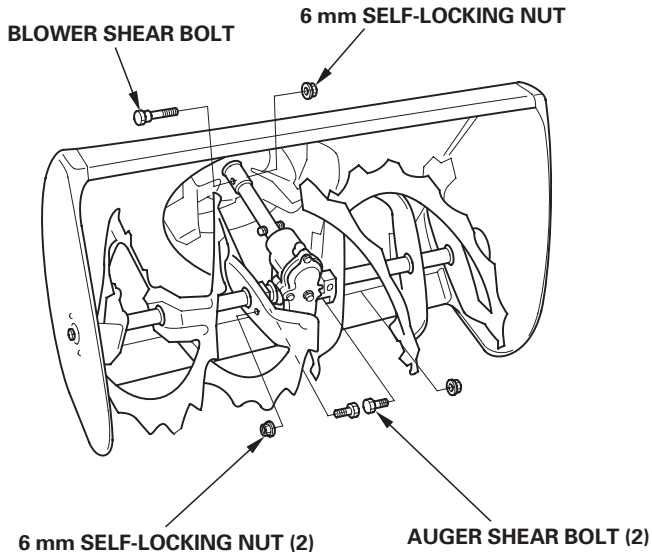

SERVICING YOUR SNOWBLOWER

SKID SHOES AND SCRAPER

Turn the engine switch to the OFF position, and disconnect the spark plug cap, so the engine cannot be accidentally started while you are near the auger.

Inspection

1. Raise the auger housing off the ground.

Track type: Step on the foot pedal (page 14), and raise the auger to the highest position.

Wheel type: Place a block of wood under the scraper to support the auger.

2. Measure the thickness of the right and left skid shoes at their thinnest point.

Replace the skid shoes if they are worn to the specified service limit.

A=NEW thickness

B=WORN thickness

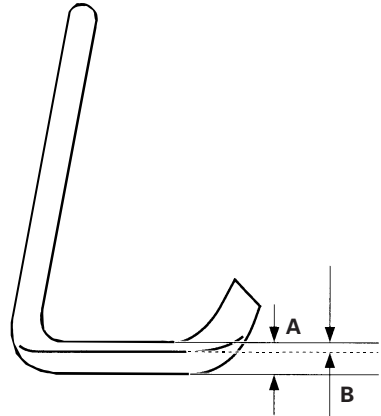

SKID SHOE SERVICE LIMIT

Rear-mount type	3/32 in (2.5 mm)
Side-mount type	1/16 in (1.5 mm)

SERVICING YOUR SNOWBLOWER

Adjustment

1. Place the snowblower on a level surface. (For track-type snowblowers, step on the foot pedal, and set the auger in the middle position.)
2. Loosen the skid shoe nuts, and adjust the skid shoes to obtain the auger ground clearance for snow conditions recommended below. Adjust the right and left skid shoes equally. Retighten the nuts securely.

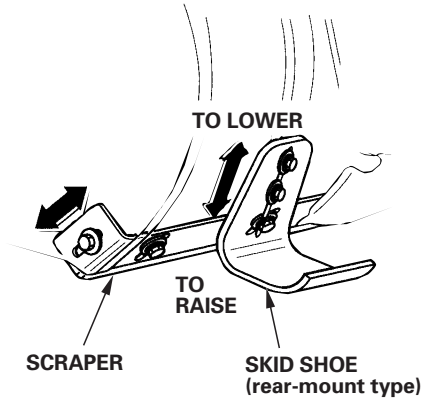

AUGER GROUND CLEARANCE RECOMMENDATIONS

For ordinary snow conditions	5/32 – 5/16 in (4.0 – 8.0 mm)
For smooth, ice-covered surfaces	3/32 – 3/16 in (2.0 – 5.0 mm)
For rough or uneven surfaces	1 – 1-3/16 in (25.0 – 30.0 mm)

NOTICE

Operation on rough or uneven surfaces with less than the recommended auger ground clearance can damage the snowblower.

3. Loosen all the nuts holding the scraper, and adjust the scraper to the specified ground clearance. Retighten the nuts securely.

SCRAPER GROUND CLEARANCE

3/32 – 5/32 in (2.0 – 4.0 mm)

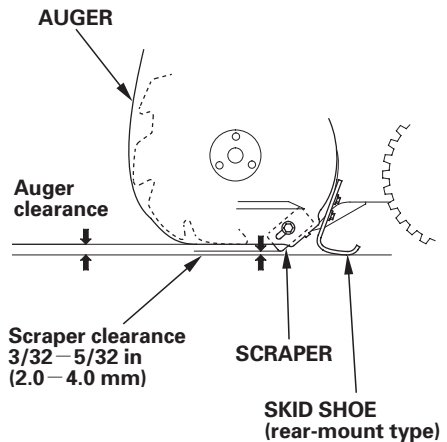

4. Inspect the scraper. Replace the scraper if it is excessively worn.

STORAGE

STORAGE PREPARATION

Proper storage preparation is essential for keeping your snowblower trouble-free and looking good. The following steps will help to keep rust and corrosion from impairing your snowblower's function and appearance, and will make the engine easier to start when you use the snowblower again.

Cleaning

1. Rinse the auger housing and wheels (or tracks) with a garden hose. Wipe the rest of the snowblower with a moist rag.
2. After the snowblower has dried, touch up any damaged paint.
3. Apply grease to the following areas for lubrication.

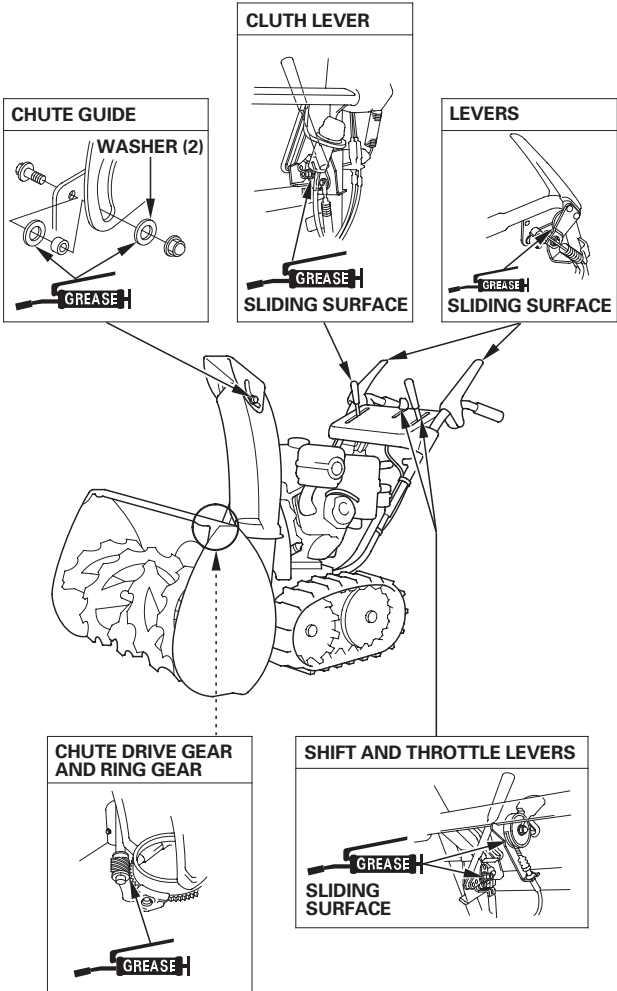

Fuel

Gasoline will oxidize and deteriorate in storage. Old gasoline will cause hard starting, and it leaves gum deposits that clog the fuel system. If the gasoline in your snowblower deteriorates during storage, you may need to have the carburetor and other fuel system components serviced or replaced.

The length of time that gasoline can be left in your fuel tank and carburetor without causing functional problems will vary with such factors as gasoline blend, your storage temperatures, and whether the fuel tank is partially or completely filled. The air in a partially filled fuel tank promotes fuel deterioration. Very warm storage/temperatures accelerate fuel deterioration. Fuel deterioration problems may occur within a few months, or even less if the gasoline was not fresh when you filled the fuel tank.

The *Distributor's Limited Warranty* does not cover fuel system damage or engine performance problems resulting from neglected storage preparation.

You can extend fuel storage life by adding a fuel stabilizer that is formulated for that purpose, or you can avoid fuel deterioration problems by draining the fuel tank and carburetor.

STORAGE

Adding a Fuel Stabilizer to Extend Fuel Storage Life

When adding a fuel stabilizer, fill the fuel tank with fresh gasoline. If only partially filled, air in the tank will promote fuel deterioration during storage. If you keep a container of gasoline for refueling, be sure that it contains only fresh gasoline.

Add fuel stabilizer following the manufacturer's instructions.

After adding a fuel stabilizer, run the engine outdoors for 10 minutes to be sure that treated gasoline has replaced the untreated gasoline in the carburetor.

Stop the engine, and move the fuel valve lever to the OFF position.

Draining the Fuel Tank and Carburetor

1. Place an approved gasoline container below the carburetor, and use a funnel to avoid spilling fuel.
2. Loosen the carburetor drain knob, then move the fuel valve lever to the ON position. Drain the carburetor until the fuel tank is empty.

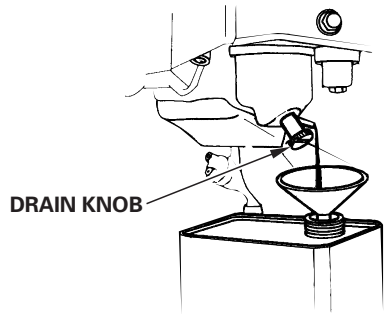

⚠ WARNING

Gasoline is highly flammable and explosive. You can be burned or seriously injured when handling fuel.

- Keep heat, sparks, and flames away.
- Handle fuel only outdoors.
- Wipe up spills immediately.

3. After draining, tighten the drain knob and turn the fuel valve OFF.
4. Remove the fuel sediment cup.
5. Empty the contents into a suitable container. Clean the fuel sediment cup.
6. Reinstall the sediment cup and O-ring and tighten securely.

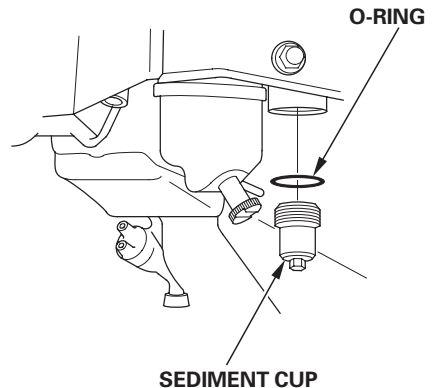

STORAGE

Engine Oil

1. Change the engine oil (page 41).
2. Remove the spark plug (page 45).
3. Pour a tablespoon (5 – 10 cc) of clean engine oil into the cylinder.
4. Pull the starter rope slowly several times to distribute the oil.
5. Reinstall the spark plug.
6. Pull the starter grip slowly until you feel resistance, then return the starter grip gently. This will close the valves so moisture cannot enter the engine cylinder.

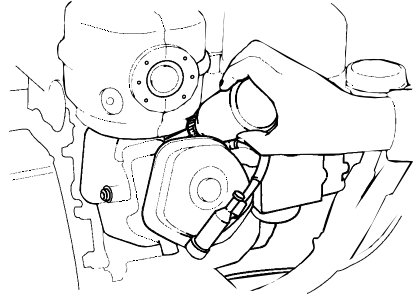

STARTER GRIP

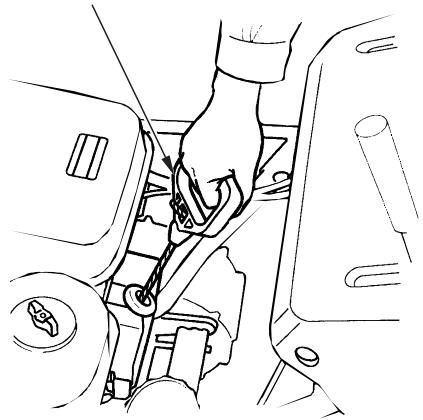

Tires

- Check the air pressure (page 48).

STORAGE PRECAUTIONS

If your snowblower will be stored with gasoline in the fuel tank and carburetor, it is important to reduce the hazard of gasoline vapor ignition. Select a well-ventilated storage area away from any appliance that operates with a flame, such as a furnace, water heater, or clothes dryer. Also avoid any area with a spark-producing electric motor, or where power tools are operated.

If possible, avoid storage areas with high humidity, because that promotes rust and corrosion.

Unless all fuel has been drained from the fuel tank, leave the fuel valve in the OFF position to reduce the possibility of fuel leakage.

Place the snowblower on a level surface. Tilting can cause fuel or oil leakage.

With the engine and exhaust system cool, cover the snowblower to keep out dust. A hot engine and exhaust system can ignite or melt some materials. Do not use sheet plastic as a dust cover. A nonporous cover will trap moisture around the engine, promoting rust and corrosion.

REMOVE FROM STORAGE

Check your snowblower as described in the *BEFORE OPERATION* chapter (page 18) of this manual.

If the fuel was drained during storage preparation, fill the tank with fresh gasoline. If you keep a container of gasoline for refueling, be sure that it contains only fresh gasoline. Gasoline oxidizes and deteriorates over time, causing hard starting.

If the cylinder was coated with oil during storage preparation, the engine may smoke briefly at startup. This is normal.

TRANSPORTING

BEFORE LOADING

1. Loading the snowblower on a trailer should be performed on a firm, level surface.
2. Use a loading ramp that is strong enough to support the combined weight of the snowblower and the operator:

Weight of snowblower: (Operating weight)

Models	HS724	HS928	HS1132
Types			
TA	203 lbs (92 kg)	245 lbs (111 kg)	267 lbs (121 kg)
TAS	—	256 lbs (116 kg)	273 lbs (124 kg)
WA	212 lbs (96 kg)	225 lbs (102 kg)	—
WAS	—	231 lbs (105 kg)	—

3. The loading ramp must be long enough so that its slope is 15° or less:

Length of Ramp (L)	8.2 ft (2.5 m)	9.8 ft (3.0 m)	11.5 ft (3.5 m)
Height (H)	1.6 ft (50 cm)	2.0 ft (60 cm)	2.3 ft (70 cm)

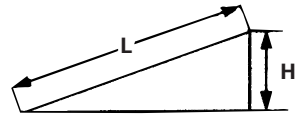

4. If the truck bed has a low roof or cover, with less than 4.9 ft (1.5 m) of headroom, lower the discharge deflector for better clearance, or remove the chute assembly.
5. Check that there is sufficient fuel in the tank. The engine may stall on the ramp if there is not enough fuel in the tank.

LOADING

1. Track type: Step on the foot pedal, and raise the auger to the HIGH position (page 14).
2. Start the engine (page 21) and maneuver the snowblower into line with the loading ramp.
3. Track type: Run the snowblower slowly up the loading ramp.

Wheel type: Push down the handles to raise the auger and run the snowblower up the loading ramp.

Be careful to avoid striking the chute or other parts of the machine.

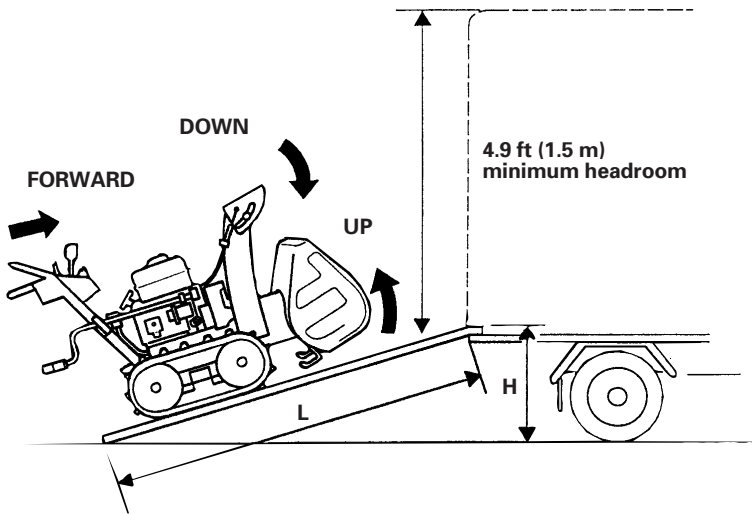

4. After the snowblower is in the truck, stop the engine, and turn the fuel valve to the OFF position. This will prevent the possibility of carburetor flooding and will reduce the possibility of fuel leakage.
5. Tie the snowblower down with rope or straps, and block the treads. Keep the tie-down rope or straps away from controls and cables.

TAKING CARE OF UNEXPECTED PROBLEMS

ENGINE PROBLEMS

Electric starter does not operate	Possible cause	Correction
Check electrical outlet.	No electric current from outlet.	Try known good electrical outlet. Start engine by using the recoil starter.
Check power cord.	Defective power cord.	Try another power cord. Start engine by using the recoil starter.

Starter operates, but engine will not start	Possible cause	Correction
Check throttle position and choke.	Throttle not in proper position.	Throttle must be in FAST position, choke OFF for a hot start, choke ON for a cold start (page 23).
Check fuel delivery to engine.	Fuel valve is OFF. Sediment cup obstructed.	Turn fuel valve to ON (page 22). Check for contaminants in sediment cup (page 55).
Check fuel condition.	Stale or old fuel.	Be sure tank has fresh fuel. Drain carburetor and sediment cup (page 55).
Check for spark.	Spark plug cap off. Improper electrode gap or deposits in the spark plug gap.	Make sure cap is connected. Verify that spark plug is free of deposits, and has proper gap (page 46).

TAKING CARE OF UNEXPECTED PROBLEMS

Engine has low power	Possible cause	Correction
Check ground speed.	Fast ground speed when blowing wet, deep snow puts excessive load on engine.	Blow snow at slower ground speed.
Snowblowing swath cut too wide for snow conditions.	Wet, deep cuts place excessive load on engine.	Reduce snowblowing swath.
Check auger housing.	Discharge chute restricted.	Clear discharge chute obstructions (page 17).
Check spark plug.	Spark plug cap not secure. Improper electrode gap or deposits on the electrodes.	Make sure spark plug cap is securely connected. Verify the spark plug is free of deposits and has the proper gap.
Check choke position.	Choke in wrong position or choke plate sticking.	Check choke plate movement.
Check fuel condition.	Stale or old fuel.	Be sure tank has fresh fuel. Drain carburetor and sediment cup (page 55).

TAKING CARE OF UNEXPECTED PROBLEMS

DRIVE PROBLEMS

Engine runs, but snowblower doesn't move	Possible cause	Correction
Check transmission release.	Lever is in the RELEASED position.	Move lever to the ENGAGED position (page 22).
Check hydrostatic transmission fluid level.	Fluid level is low.	Add hydrostatic transmission fluid to the proper level (page 44).
Check shift lever for position.	Shift lever is in "N" (neutral).	Move shift lever to forward or reverse (page 29).
Check drive clutch lever.	Drive clutch lever mechanism or cable not functioning properly.	See servicing Honda snowblower dealer.
Check drive belt.	Drive belt worn, broken or not on pulleys.	See servicing Honda snowblower dealer.

TAKING CARE OF UNEXPECTED PROBLEMS

SNOWBLOWER PROBLEMS

Won't blow snow	Possible cause	Correction
Check shear bolts.	Shear bolts broken.	Replace broken shear bolt(s) (page 49).
Check auger housing.	Discharge chute restricted. Foreign object stopping auger from rotating.	Clear discharge chute of obstructions (page 17). Remove foreign object.
Check drive belt and primary belt.	Belt worn, not on pulleys or not properly installed.	See servicing Honda snowblower dealer.

Snow not discharging properly	Possible cause	Correction
Check throttle position.	Auger spinning too slowly.	Keep throttle in FAST (page 12).
Check shear bolts.	Shear bolts broken.	Replace broken shear bolt(s) (page 49).
Check snowblower drive belt.	Belt worn, not on pulleys or not properly installed.	See servicing Honda snowblower dealer.
Check snow conditions.	Wet, deep snow is difficult to blow.	Reduce snowblowing swath (page 32).

TAKING CARE OF UNEXPECTED PROBLEMS

Snow not discharging properly (cont.)	Possible cause	Correction
Check ground speed.	Snowblower moving too fast for snow conditions.	Use shift lever to reduce ground speed (page 29).

Engine stalls when auger clutch lever is set to On	Possible cause	Correction
Check throttle position.	Engine running too slow.	Keep throttle in FAST when engaging auger clutch (page 12).
Check auger housing.	Discharge chute restricted. Foreign object stopping auger from rotating. Auger frozen by ice.	Clear discharge chute or auger housing of obstruction (page 17).

TECHNICAL & CONSUMER INFORMATION

TECHNICAL INFORMATION

Serial Number Locations

Record the engine and frame serial numbers in the spaces below. You will need these serial numbers when ordering parts, and when making technical or warranty inquiries (see page 74).

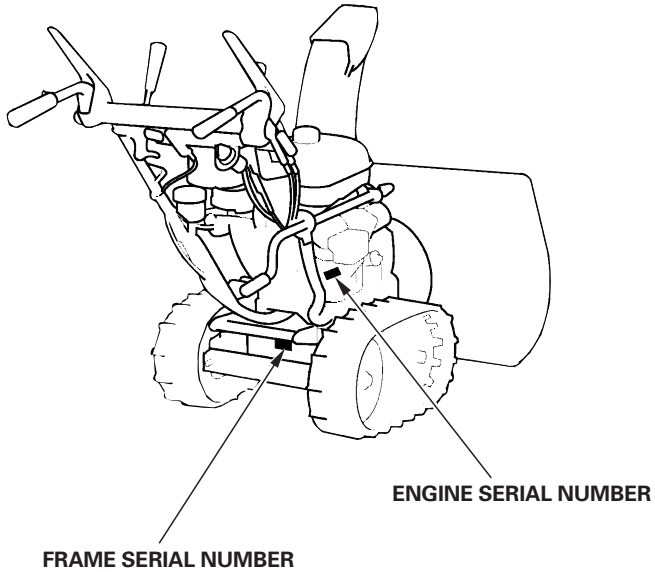

Engine serial number: _____

Frame serial number: _____

Date of purchase: _____

TECHNICAL & CONSUMER INFORMATION

Carburetor Modification for High Altitude Operation

At high altitude, the standard carburetor air-fuel mixture will be too rich. Performance will decrease, and fuel consumption will increase. A very rich mixture will also foul the spark plug and cause hard starting. Operation at an altitude that differs from that at which this engine was certified, for extended periods of time, may increase emissions.

High altitude performance can be improved by specific modifications to the carburetor. If you always operate your pump at altitudes above 5,000 feet (1,500 meters) have your servicing dealer perform this carburetor modification. This engine, when operated at high altitude with the carburetor modifications for high altitude use, will meet each emission standard throughout its useful life.

Even with carburetor modification, engine horsepower will decrease about 3.5 % for each 1,000-foot (300-meter) increase in altitude. The effect of altitude on horsepower will be greater than this if no carburetor modification is made.

NOTICE

When the carburetor has been modified for high altitude operation, the air-fuel mixture will be too lean for low altitude use. Operation at altitudes below 5,000 feet (1,500 meters) with a modified carburetor may cause the engine to overheat and result in serious engine damage. For use at low altitudes, have your servicing dealer return the carburetor to original factory specifications.

Emission Control System Information

Source of Emissions

The combustion process produces carbon monoxide, oxides of nitrogen, and hydrocarbons. Control of hydrocarbons and oxides of nitrogen is very important because, under certain conditions, they react to form photochemical smog when subjected to sunlight. Carbon monoxide does not react in the same way, but it is toxic.

Honda utilizes appropriate air/fuel ratios and other emissions control systems to reduce the emissions of carbon monoxide, oxides of nitrogen and hydrocarbons.

The U.S. and California Clean Air Act

EPA and California regulations require all manufacturers to furnish written instructions describing the operation and maintenance of emission control systems.

The following instructions and procedures must be followed in order to keep the Honda engine emissions within the emission standards.

Tampering and Altering

Tampering with or altering the emission control system may increase emissions beyond the legal limit. Among those acts that constitute tampering are:

- Removal or alteration of any part of intake, fuel or exhaust system.
- Altering or defeating the governor linkage or speed-adjusting mechanism to cause the engine to operate outside its design parameters.

TECHNICAL & CONSUMER INFORMATION

Problems That May Affect Emissions

If you are aware of any of the following symptoms, have your engine inspected and repaired by your authorized Honda servicing dealer.

- Hard starting or stalling after starting.
- Rough idle.
- Misfiring or backfiring under load.
- Afterburning (backfiring).
- Black exhaust smoke or high fuel consumption.

Replacement parts

The emission control systems on your new Honda engine were designed, built, and certified to conform with EPA and California emission regulations. We recommend the use Honda Genuine parts whenever you have maintenance done. These original-design replacement parts are manufactured to the same standards as the original parts, so you can be confident of their performance. The use of replacement parts that are not of the original design and quality may impair the effectiveness of your emission control system.

A manufacturer of an aftermarket part assumes the responsibility that the part will not adversely affect emission performance. The manufacturer or rebuilder of the part must certify that use of the part will not result in a failure of the engine to comply with emission regulations.

Maintenance

Follow the *Maintenance Schedule* on page 37 . Remember that this schedule is based on the assumption that your machine will be used for its designed purpose. Sustained high-load operation will require more frequent service.

TECHNICAL & CONSUMER INFORMATION

Air Index

An Air Index Information hang tag/label is applied to engines certified to an emission durability time period in accordance with the requirements of the California Air Resources Board.

The bar graph is intended to provide you, our customer, the ability to compare the emissions performance of available engines. The lower the Air Index, the less pollution.

The durability description is intended to provide you with information relating to the engine's emission durability period. The descriptive term indicates the useful-life period for the engine's emission control system. See your *Emission Control Warranty* for additional information.

Descriptive Term	Applicable to Emission Durability Period
Moderate	50 hours (0 – 80 cc, inclusive)
	125 hours (greater than 80 cc)
Intermediate	125 hours (0 – 80 cc, inclusive)
	250 hours (greater than 80 cc)
Extended	300 hours (0 – 80 cc, inclusive)
	500 hours (greater than 80 cc)
	1,000 hours (225 cc and greater)

TECHNICAL & CONSUMER INFORMATION

Specifications

Frame

Model	HS724	
Type	TA	WA
Discription code	SZBE	
Overall length	53.4 in (1,357 mm)	55.9 in (1,420 mm)
Overall width	24.4 in (620 mm)	
Overall height	38.2 in (970 mm)	41.0 in (1,042 mm)
Dry mass [weight]	194 lbs (88 kg)	203 lbs (92 kg)
Width of snow clearance	23.8 in (605 mm)	
Height of snow clearance	16.5 in (420 mm)	20.1 in (510 mm)
Snow throwing distance (varies with snow conditions)	Max. 45.9 ft (14 m)	
Clearing capacity	42 Ton/hour	46 Ton/hour
Continuous operating time (varies with snow conditions)	1.8 hours	3.1 hours

Engine

Model	Honda GX200
Displacement	12.0 cu-in (196 cm ³)
Bore × stroke	2.68 × 2.13 in (68.0 × 54.0 mm)
Starting method	Recoil starter
Ignition system	Transistor magneto
Oil capacity	0.63 US qt (0.60 ℓ)
Fuel tank capacity	0.82 US gal (3.1 ℓ)
Spark plug	BPR5ES (NGK) W16EPR-U (DENSO)

Tuneup

ITEM	SPECIFICATION	MAINTENANCE
Spark plug gap	0.028 – 0.031 in (0.7 – 0.8 mm)	Refer to page: 45
Valve clearance	IN: 0.15 ± 0.02 mm EX: 0.20 ± 0.02 mm	See your authorized Honda dealer
Other specifications	No other adjustments needed.	

Specifications are subject to change without notice.

TECHNICAL & CONSUMER INFORMATION

Frame

Model	HS928			
Type	TA	TAS	WA	WAS
Items	SZAS			
Discription code	SZAS			
Overall length	56.0 in (1,422 mm)		55.1 in (1,400 mm)	57.2 in (1,452 mm)
Overall width	28.5 in (725 mm)			
Overall height	40.9 in (1,038 mm)		41.0 in (1,042 mm)	
Dry mass [weight]	231 lbs (105 kg)	240 lbs (109 kg)	212 lbs (96 kg)	218 lbs (99 kg)
Width of snow clearance	28.0 in (710 mm)			
Height of snow clearance	20.1 in (510 mm)			
Snow throwing distance (varies with snow conditions)	Max. 49.2 ft (15 m)			
Clearing capacity	50 Ton/hour			
Continuous operating time (varies with snow conditions)	2.1 hours			

Engine

Model	Honda GX270
Displacement	16.5 cu-in (270 cm ³)
Bore × stroke	3.03 × 2.28 in (77.0 × 58.0 mm)
Starting method	Recoil starter or AC electric starter
Ignition system	Transistor magneto
Oil capacity	1.16 US qt (1.10 ℓ)
Fuel tank capacity	1.32 US gal (5.0 ℓ)
Spark plug	BPR5ES (NGK) W16EPR-U (DENSO)

Tuneup

ITEM	SPECIFICATION	MAINTENANCE
Spark plug gap	0.028 – 0.031 in (0.7 – 0.8 mm)	Refer to page: 45
Valve clearance	IN: 0.15 ± 0.02 mm EX: 0.20 ± 0.02 mm	See your authorized Honda dealer
Other specifications	No other adjustments needed.	

Specifications are subject to change without notice.

TECHNICAL & CONSUMER INFORMATION

Frame

Model		HS1132	
Type		TA	TAS
Items			
Discription code		SZBF	
Overall length		56.0 in (1,422 mm)	
Overall width		31.9 in (810 mm)	
Overall height		40.2 in (1,022 mm)	
Dry mass [weight]		254 lbs (115 kg)	260 lbs (118 kg)
Width of snow clearance		31.9 in (810 mm)	
Height of snow clearance		20.1 in (510 mm)	
Snow throwing distance (varies with snow conditions)		Max. 55.8 ft (17 m)	
Clearing capacity		65 Ton/hour	
Continuous operating time (varies with snow conditions)		2.2 hours	

Engine

Model	Honda GX340K1	
Displacement	20.6 cu-in (337 cm ³)	
Bore × stroke	3.23 × 2.52 in (82.0 × 64.0 mm)	
Starting method	Recoil starter	AC electric starter
Ignition system	Transistor magneto	
Oil capacity	1.16 US qt (1.10 ℓ)	
Fuel tank capacity	1.51 US gal (5.7 ℓ)	
Spark plug	BPR5ES (NGK) W16EPR-U (DENSO)	

Tuneup

ITEM	SPECIFICATION	MAINTENANCE
Spark plug gap	0.028 – 0.031 in (0.7 – 0.8 mm)	Refer to page: 45
Valve clearance	IN: 0.15 ± 0.02 mm EX: 0.20 ± 0.02 mm	See your authorized Honda dealer
Other specifications	No other adjustments needed.	

Specifications are subject to change without notice.

TECHNICAL & CONSUMER INFORMATION

CONSUMER INFORMATION

DEALER LOCATOR INFORMATION

To find an authorized Honda Servicing Dealer anywhere in the United States:

Call (800) 426-7701 or visit our web site:

www.hondapowerequipment.com/dea.htm

Honda PUBLICATIONS

Shop Manual

This manual covers complete maintenance and overhaul procedures. It is intended to be used by a skilled technician.

Available through your Honda dealer or through Helm Inc. at 1 888-292-5395 or visit www.hondapowerequipment.com/own.htm

Parts Catalog

This manual provides complete, illustrated parts lists. Available through your Honda dealer.

TECHNICAL & CONSUMER INFORMATION

Customer Service Information

Servicing dealership personnel are highly trained professionals. They should be able to answer any question you may have. If you encounter a problem that your dealer does not solve to your satisfaction, please discuss it with the dealership's management. The Service Manager or General Manager can help. Almost all problems are solved in this way.

If you are dissatisfied with the decision made by the dealership's management, contact the Honda Power Equipment Customer Relations Office. You can write:

American Honda Motor Co., Inc.
Power Equipment Division
Customer Relations Office
4900 Marconi Drive
Alpharetta, Georgia 30005-8847

Or telephone: (770) 497-6400 8:30 am to 7:00 pm ET

When you write or call, please give us this information:

- Model and serial number (see page 65)
- Name of the dealer who sold the snowblower to you
- Name and address of the dealer who services your snowblower
- Date of purchase
- Your name, address, and telephone number
- A detailed description of the problem

MEMO

MEMO

QUICK REFERENCE INFORMATION

Fuel	Type	Unleaded gasoline with a pump octane rating of 86 or higher
Engine Oil	Type	SAE 5W-30 API SJ or later for general use
Spark Plug	Type	BPR5ES (NGK) W16EPR-U (DENSO)
Tires	Tire Pressure	8.5 psi (59 kPa , 0.6 kgf/cm ²)
Maintenance	Before each use, check the following.	Engine oil level. Tire air pressure. Transmission oil level. Auger skid shoes and scraper.
	First 20 hours	Change engine oil.
	Subsequent	See Maintenance Schedule (page 37)

HONDA

The Power of Dreams

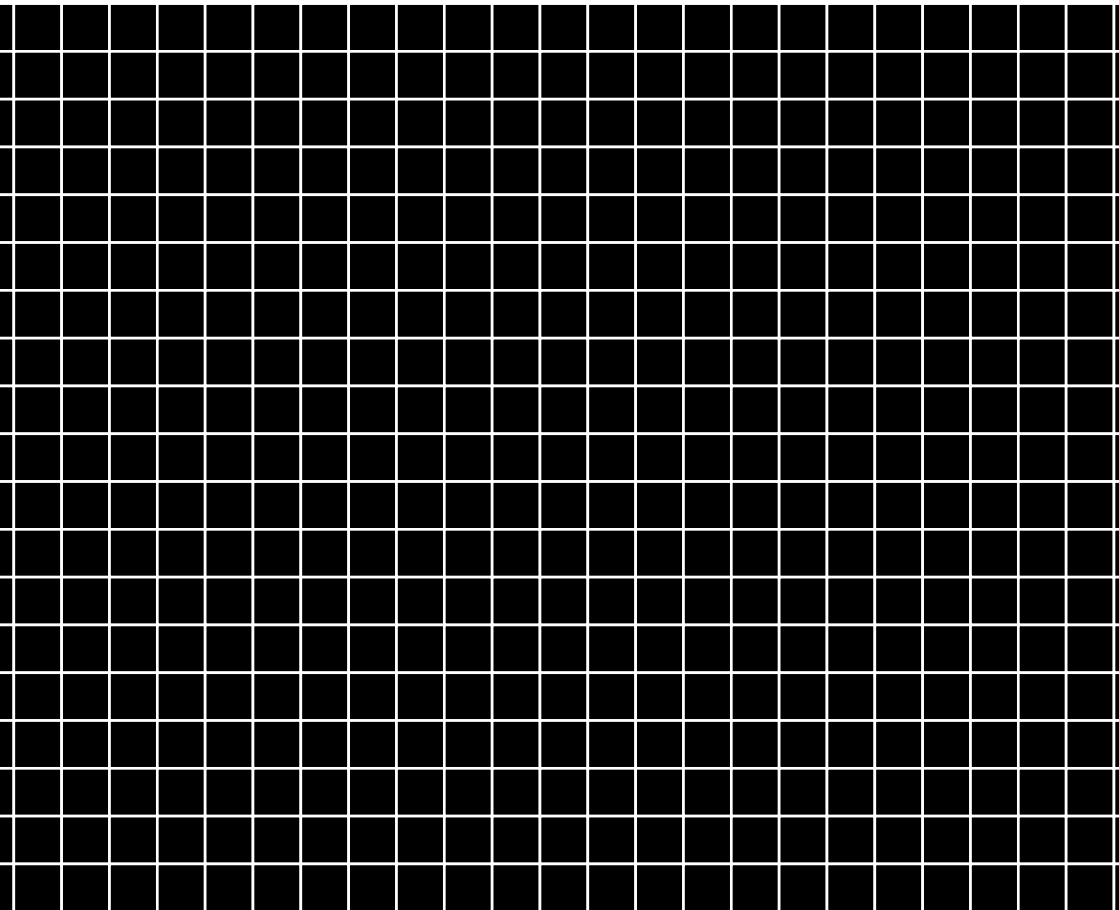

31767723
00X31-767-7231



3000.2008.04

Printed in Japan