

# REPAIR PARTS

# AUGER HOUSING / IMPELLER ASSEMBLY

SNOW THROWER - MODEL NO. **8527SBE** (96193000300), PRODUCT NO. 961 93 00-03

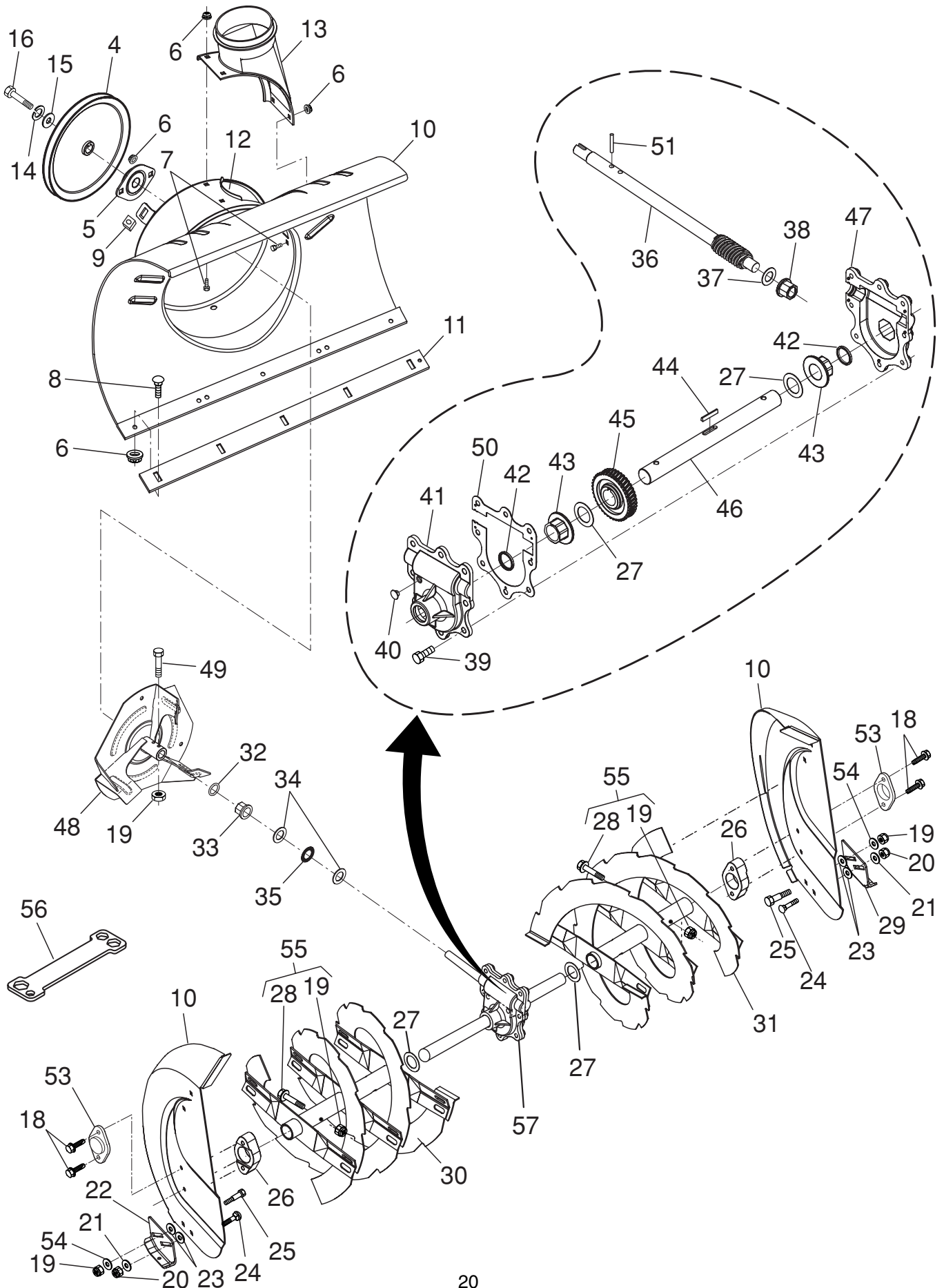

**REPAIR PARTS****AUGER HOUSING / IMPELLER ASSEMBLY****SNOW THROWER - MODEL NO. 8527SBE (96193000300), PRODUCT NO. 961 93 00-03**

KEY NO.	PART NO.	DESCRIPTION
4	532 19 10-79	Pulley, Impeller
5	532 18 89-09	Bearing Assembly, Flange
6	532 15 53-77	Nut, Hex Flange 5/16-18
7	532 18 03-55	Bolt, Flat Head, Carriage 5/16-18 x 5/8
8	872 27 05-05	Bolt, Carriage 5/16-18 x 5/8
9	532 17 88-20	Nut, Cage 3/8-16
10	532 18 82-11	Housing, Auger
11	532 18 40-90	Bar, Scraper
12	532 18 40-95	Bracket, Corner Discharge
13	532 17 53-22	Base, Discharge Chute
14	819 11 15-07	Washer, Flat
15	810 04 05-00	Washer, Lock 5/16
16	874 95 05-12	Screw, Hex Head 5/16-18 x 3/4
18	532 17 95-82	Screw, Hex Head 5/16 x 1
19	873 80 04-00	Nut, Hex Lock 1/4-20
20	873 80 05-00	Nut, Hex Lock 5/16-18
21	532 15 54-15	Washer, Flat 5/16
22	532 18 40-94	Skid Plate, RH
23	532 17 92-46	Washer, Nylon, Friction
24	872 27 05-06	Bolt, Carriage 5/16-18 x 3/4
25	532 18 56-00	Bolt, Shoulder 1/4-20
26	532 18 81-70	Bearing Retainer, Plastic
27	532 17 46-97	Washer, Thrust, 1"
28	532 19 20-90	Bolt, Shear
29	532 18 40-93	Skid Plate, LH
30	532 19 95-73	Auger Assembly, RH
31	532 19 95-72	Auger Assembly, LH
32	532 17 46-99	O-Ring
33	532 17 47-00	Bushing, Flange 3/4
34	532 17 46-81	Washer, Thrust 3/4
35	532 17 46-84	Bearing, Thrust 3/4
36	532 17 46-60	Shaft, Impeller
37	532 17 46-83	Washer, Thrust 5/8
38	532 17 46-86	Bushing, Flange 5/8
39	532 15 00-78	Screw, Hex Head 5/16-18 x 3/4
40	532 08 64-47	Plug, Case
41	532 17 46-88	Housing, Gearbox, RH
42	532 17 46-98	Seal, Oil
43	532 17 47-01	Bushing, Flange, 1"
44	532 18 92-82	Key, Square 1/4 x 1/4 x 7/8
45	532 17 46-59	Gear, Worm
46	532 17 46-57	Shaft, Auger
47	532 17 46-87	Housing, Gearbox, LH
48	532 18 41-05	Impeller Assembly
49	874 78 04-26	Screw, Hex Head 1/4-20 x 1-5/8
50	532 17 53-11	Gasket, Gearbox
51	532 18 42-05	Pin, Roll 3/16 x 1-1/8
53	532 18 79-25	Bearing, Auger
54	532 05 38-47	Washer, Flat 1/4
55	532 18 82-43	Kit, Shear (Contains 6 each of Key Numbers 19 and 28)
56	532 18 06-84	Multi-Wrench
57	<b>532 17 88-77</b>	<b>Gearbox Assembly</b>

**NOTE:** All component dimensions given in U.S. inches. 1 inch = 25.4 mm**IMPORTANT:** Use only Original Equipment Manufacturer (O.E.M.) replacement parts. Failure to do so could be hazardous, damage your lawn mower and void your warranty.

# REPAIR PARTS

# CONTROL PANEL / DISCHARGE CHUTE

SNOW THROWER - MODEL NO. **8527SBE** (96193000300), PRODUCT NO. 961 93 00-03

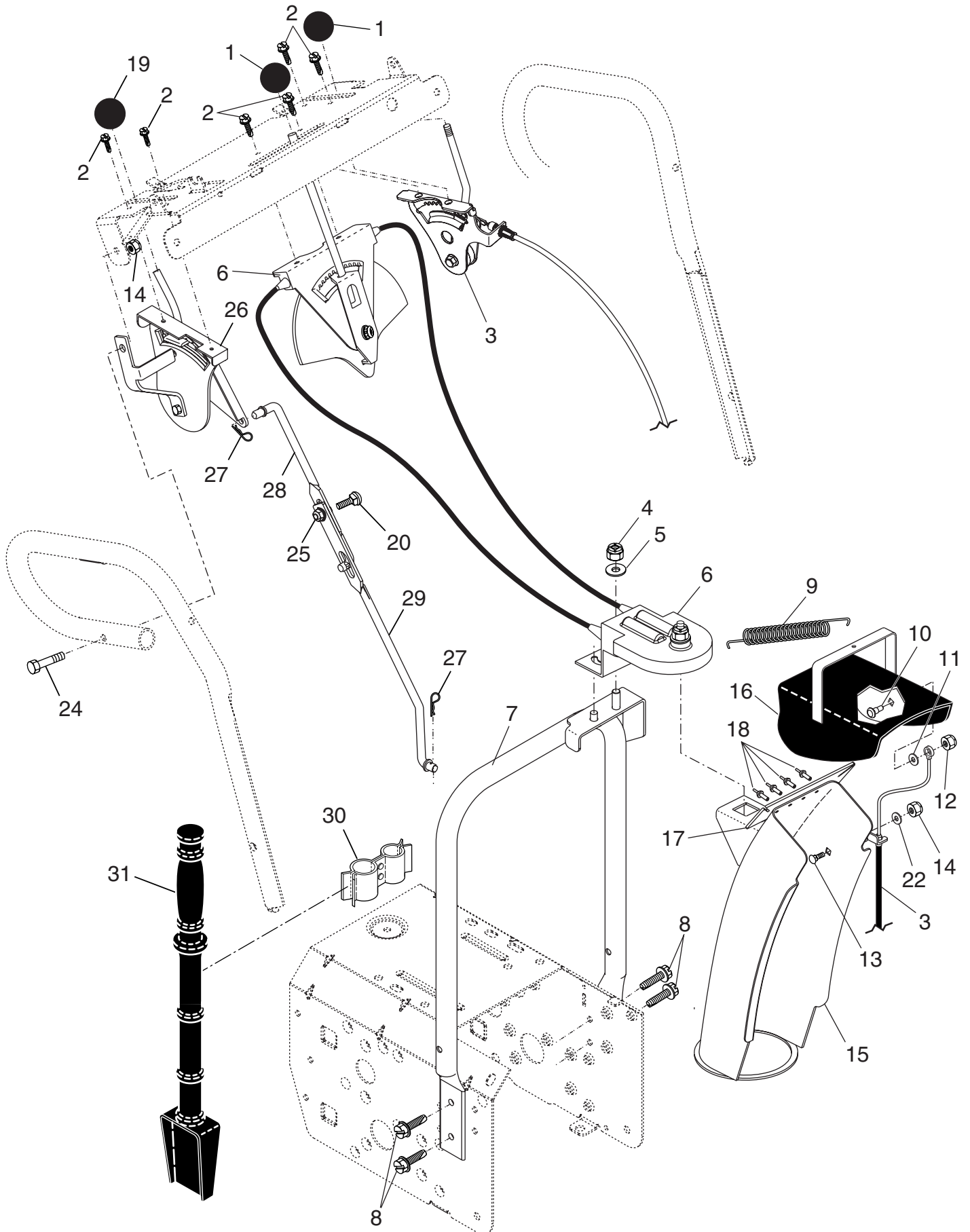

# REPAIR PARTS

# CONTROL PANEL / DISCHARGE CHUTE

SNOW THROWER - MODEL NO. **8527SBE** (96193000300), PRODUCT NO. 961 93 00-03

KEY NO.	PART NO.	DESCRIPTION
1	532 18 33-34	Knob, Lever
2	817 50 10-10	Screw #10-24 x 5/8
3	532 17 86-74	Control Assembly, Deflector
4	873 80 06-00	Nut, Lock 3/8-16
5	819 13 13-16	Washer, Flat 3/8
6	532 17 86-59	Control Assembly, Chute Rotater
7	532 18 40-89	Support, Pivot
8	532 15 00-78	Screw, Hex Head 5/16-18 x 3/4
9	532 18 45-05	Spring, Deflector
10	532 17 98-29	Bolt, Shoulder
11	532 17 92-46	Washer, Flat 1/4
12	873 80 04-00	Nut, Lock 1/4-20
13	872 25 05-05	Bolt, Carriage 5/16-18
14	873 80 05-00	Nut, Lock 5/16-18
15	532 18 41-12	Chute Assembly
16	532 18 41-13	Deflector Assembly
17	532 17 91-45	Seal, Deflector
18	532 12 84-15	Rivet, Blind
19	532 18 33-33	Knob, Speed Control Lever
20	872 27 05-06	Bolt, Carriage 5/16-18 x 3/4
22	532 15 54-15	Washer, Flat 5/16
24	874 78 05-28	Screw, Hex Head 5/16-18 x 1-3/4
25	532 15 53-77	Nut, Lock 5/16-18
26	532 19 88-75	Lever Assembly, Speed Control
27	532 16 96-75	Retainer, Hairpin
28	532 18 04-45	Rod, Upper, Speed Control
29	532 18 77-16	Rod, Lower, Speed Control
30	532 19 27-10	Clamp, Clean-Out Tool
31	532 19 21-99	Tool, Clean-Out

**NOTE:** All component dimensions given in U.S. inches. 1 inch = 25.4 mm

**IMPORTANT:** Use only Original Equipment Manufacturer (O.E.M.) replacement parts. Failure to do so could be hazardous, damage your lawn mower and void your warranty.

# REPAIR PARTS

# HANDLES

SNOW THROWER - MODEL NO. **8527SBE** (96193000300), PRODUCT NO. 961 93 00-03

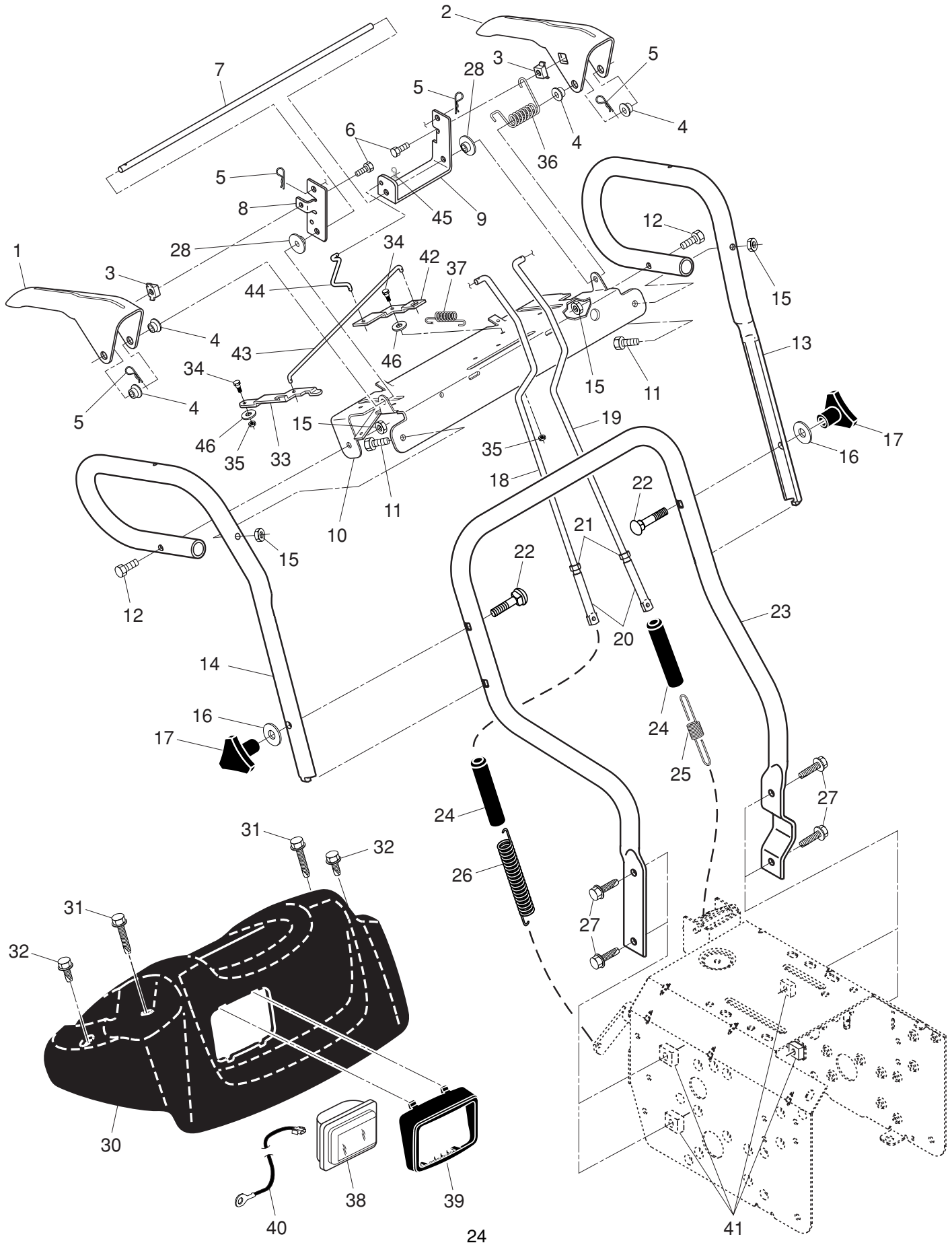

**REPAIR PARTS****HANDLES****SNOW THROWER - MODEL NO. 8527SBE (96193000300), PRODUCT NO. 961 93 00-03**

KEY NO.	PART NO.	DESCRIPTION
1	532 18 41-10	Lever, Auger Control, RH
2	532 18 41-09	Lever, Traction Drive Control, LH
3	532 17 94-39	Nut, Cage 1/4-20
4	532 17 88-88	Bushing, Flange
5	532 16 96-75	Retainer, Hairpin
6	532 18 04-02	Screw, Hex Head 1/4-20 x 3/4
7	532 17 86-52	Rod, Interlock
8	532 19 95-76	Arm, Impeller Rod
9	532 19 95-75	Arm, Traction Rod
10	532 19 95-31	Panel, Control
11	874 78 05-24	Screw, Hex Head 5/16-18 x 1-1/2
12	874 78 05-28	Screw, Hex Head 5/16-18 x 1-3/4
13	532 18 41-07	Handle Tube, LH
14	532 18 41-08	Handle Tube, RH
15	873 80 05-00	Nut, Lock 5/16-18
16	819 13 13-16	Washer, Flat 3/8
17	532 17 88-99	Knob, Handle
18	532 18 45-94	Rod, Auger Control
19	532 19 30-81	Rod, Traction Control
20	532 18 04-28	End, Control Rod
21	873 35 05-00	Nut, Hex, Jam 5/16-18
22	872 12 06-18	Bolt, Carriage 3/8-16 x 2-1/4
23	532 18 40-87	Handle Tube, Lower
24	532 18 04-47	Sleeve, Spring
25	532 18 09-26	Spring, Traction Drive
26	532 17 86-69	Spring, Auger Control
27	871 21 06-16	Screw, Hex Head 3/8-16 x 1
28	532 17 53-31	Bushing, Pivot Lever
30	532 18 29-06	Console, Panel
31	532 17 52-62	Screw, Hex Head, Tapping #10-24 x 1-1/4
32	532 18 44-71	Screw, Hex Head, Tapping #10-24 x 1/2
33	532 19 95-77	Latch, Interlock
34	532 18 35-18	Bolt, Shoulder
35	532 06 80-38	Nut, Lock 1/4-20
36	532 17 88-31	Spring, Torsion
37	532 19 38-85	Spring, Interlock
38	532 17 86-66	Headlight, Halogen (Includes Bulb)
--	<b>532 40 16-20</b>	Bulb, Halogen
39	532 17 86-68	Bezel, Headlight
40	532 18 09-64	Harness, Headlight (Halogen)
41	532 17 88-90	Nut, Cage 3/8-16
42	532 19 95-78	Lever, Interlock
43	532 19 63-37	Rod, Latch, Interlock
44	532 19 63-38	Rod, Arm, Interlock
45	532 70 02-79	Clip
46	532 17 92-46	Washer, Friction

**NOTE:** All component dimensions given in U.S. inches. 1 inch = 25.4 mm**IMPORTANT:** Use only Original Equipment Manufacturer (O.E.M.) replacement parts. Failure to do so could be hazardous, damage your lawn mower and void your warranty.

# REPAIR PARTS

# DRIVE

SNOW THROWER - MODEL NO. **8527SBE** (96193000300), PRODUCT NO. 961 93 00-03

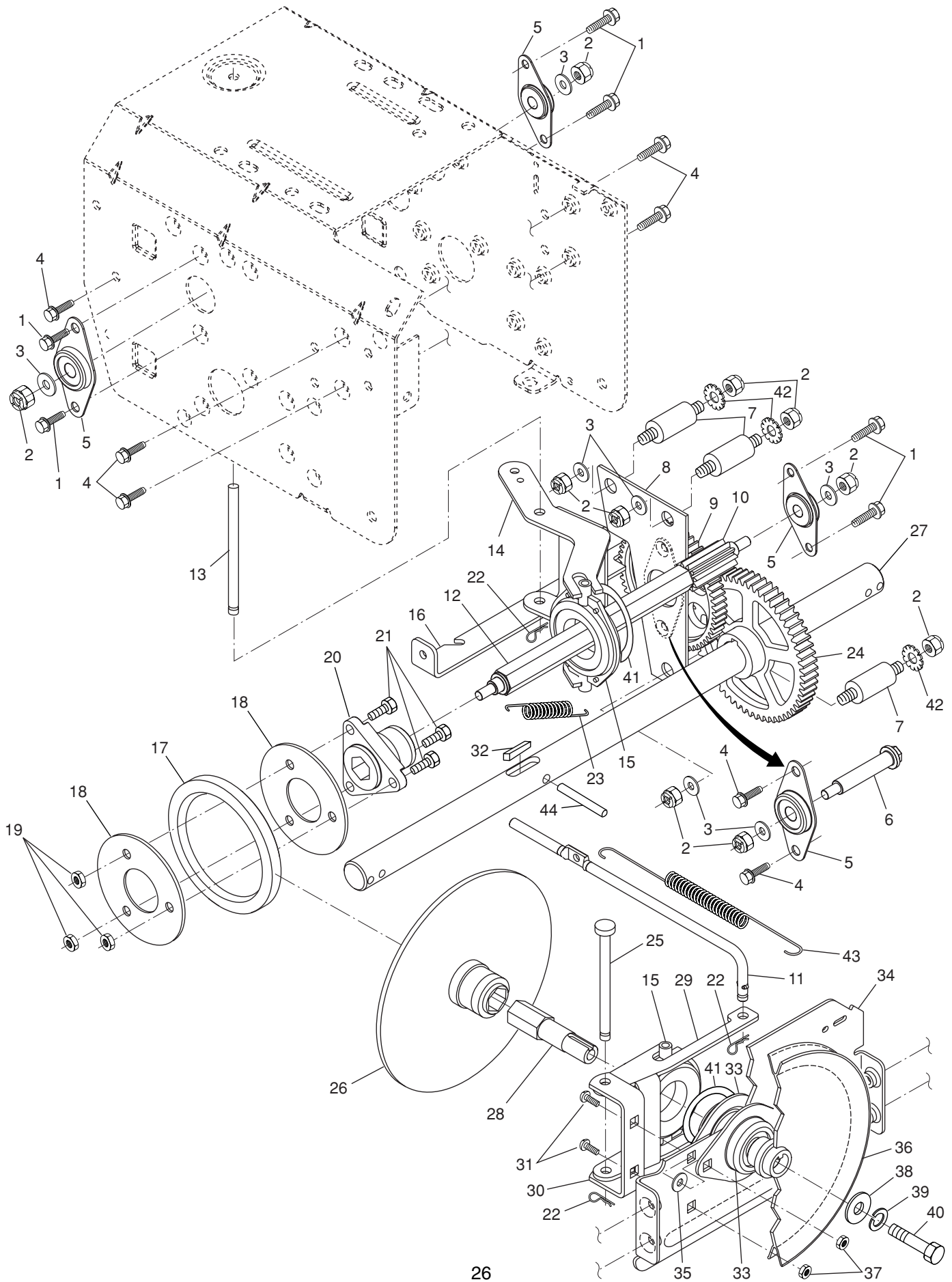

**REPAIR PARTS****DRIVE****SNOW THROWER - MODEL NO. 8527SBE (96193000300), PRODUCT NO. 961 93 00-03**

KEY NO.	PART NO.	DESCRIPTION
1	532 14 63-15	Screw, Hex Head 5/16-18 x 3/4
2	873 80 05-00	Nut, Lock 5/16-18
3	532 15 54-15	Washer, Flat
4	817 49 05-08	Screw, Hex Head 5/16-18 x 1/2
5	532 18 00-17	Bearing, Flange
6	532 18 01-34	Shaft, Auxiliary
7	532 17 92-70	Spacer, Plate
8	532 19 29-07	Plate, Auxiliary
9	532 18 00-82	Gear, Intermediate (12/58)
10	532 18 00-65	Gear, Pinion
11	532 18 77-14	Rod, Clutch
12	532 18 00-66	Shaft, Long, Hex
13	532 17 88-07	Pin, Pivot
14	532 18 40-80	Lever, Shifter / Wheel
15	532 17 53-44	Trunnion Bearing Assembly
16	532 18 78-57	Bracket, Pivot, Shift
17	532 17 98-31	Ring, Rubber Wheel
18	532 19 95-09	Plate, Rubber Wheel
19	873 93 05-00	Nut, Lock 5/16-18
20	532 17 86-13	Hub, Rubber Wheel
21	874 76 05-14	Screw, Hex Head 5/16-18 x 7/8
22	532 08 51-79	Retainer, Hairpin
23	532 18 01-35	Spring, Bias
24	532 18 00-81	Gear, Axle (58 Teeth)
25	532 17 86-95	Pin, Pivot Lever
26	532 19 77-63	Plate Assembly, Drive
27	532 17 93-52	Shaft, Axle
28	532 19 77-64	Shaft, Short Hex
29	532 18 40-77	Lever, Shifter Plate
30	532 18 40-76	Bracket, Shifter Support
31	872 27 05-05	Bolt, Carriage 5/16-18 x 5/8
32	532 18 92-82	Key, Square
33	532 18 89-09	Bearing, Flange
34	532 18 40-75	Plate, Drive Mounting
35	532 18 25-04	Spacer, Bearing
36	532 19 10-80	Pulley, Traction Drive
37	532 15 53-77	Nut, Lock 5/16-18
38	819 11 15-07	Washer, Flat
39	810 04 05-00	Washer, Lock 5/16
40	874 95 05-12	Screw, Hex Head 5/16-18 x 3/4
41	812 00 00-12	Ring, Retaining
42	811 05 05-00	Washer, Lock, External Tooth 5/16
43	532 17 90-95	Spring, Return
44	532 18 42-06	Pin, Roll

**NOTE:** All component dimensions given in U.S. inches. 1 inch = 25.4 mm**IMPORTANT:** Use only Original Equipment Manufacturer (O.E.M.) replacement parts. Failure to do so could be hazardous, damage your lawn mower and void your warranty.

# REPAIR PARTS

# CHASSIS / ENGINE / PULLEYS

SNOW THROWER - MODEL NO. **8527SBE** (96193000300), PRODUCT NO. 961 93 00-03

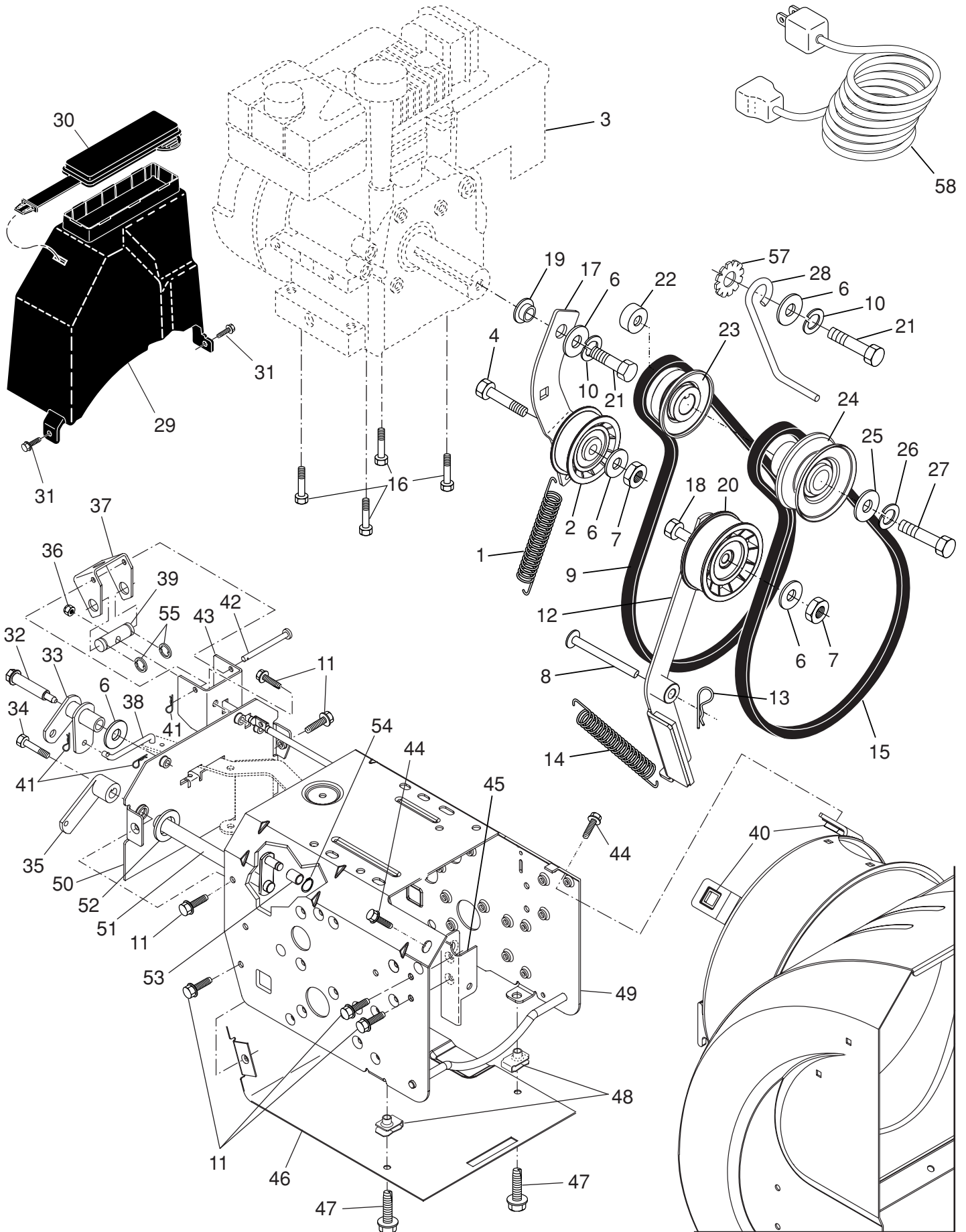

# REPAIR PARTS

# CHASSIS / ENGINE / PULLEYS

SNOW THROWER - MODEL NO. **8527SBE** (96193000300), PRODUCT NO. 961 93 00-03

KEY PART NO.	PART NO.	DESCRIPTION	KEY PART NO.	PART NO.	DESCRIPTION
1	532 18 10-44	Spring, Traction Idler	29	532 19 22-13	Belt Cover Assembly (Includes Toolbox Cover)
2	532 18 05-22	Pulley, Idler (2-1/4)	30	532 17 88-30	Cover, Toolbox
3	- - -	Engine, Tecumseh, Model Number LH185A (For engine service and replacement parts, call Tecumseh Products at 1-800-558-5402)	31	817 49 04-08	Screw, Hex Head 1/4-20 x 1/2
4	874 78 05-20	Screw, Hex Head 5/16-18 x 1-1/4	32	532 17 92-56	Bolt, Shoulder 5/16-18
6	532 05 92-89	Washer, Flat	33	532 18 78-53	Bellcrank Shifter
7	873 93 05-00	Nut, Jam, Lock 5/16-18	34	532 18 04-01	Screw, Hex Head 1/4-28 x 3/4
8	532 17 53-30	Pin, Idler Pivot	35	532 19 57-67	Arm, Auger Control
9	532 17 90-92	V-Belt, Traction Drive	36	873 80 05-00	Nut, Lock 5/16-18
10	810 04 05-00	Washer, Lock 5/16	37	532 18 40-86	Bellcrank
11	817 49 05-08	Screw, Hex Head 5/16-18 x 1/2	38	532 18 71-01	Link, Speed Control
12	532 17 92-59	Impeller Idler Arm Assembly	39	532 19 21-10	Trunnion, Pivot Bracket
13	532 08 51-79	Retainer, Hairpin	40	532 17 88-20	Nut, Cage 3/8-16
14	532 17 88-28	Spring, Brake	41	532 70 02-79	Hairpin, Cotter 3/32 x 1/2
15	532 18 35-33	V-Belt, Impeller Drive	42	532 17 90-65	Pin, Pivot Bracket
16	532 19 23-06	Screw, Hex Head 3/8-16 x 1-1/4	43	532 18 40-85	Bracket, Bellcrank
17	532 18 48-04	Arm, Idler	44	871 21 06-16	Screw, Hex Head
18	874 78 05-24	Screw, Hex Head 5/16-18 x 1-1/2	45	532 18 40-74	Pivot Bracket, Impeller Idler Arm
19	532 17 53-31	Bushing, Idler Pivot	46	532 18 40-84	Pan, Frame Bottom
20	532 18 05-23	Pulley, Idler (2-3/4)	47	871 02 05-12	Screw, Hex Head 5/16-18 x 3/4
21	874 61 05-16	Screw, Hex Head 5/16-18 x 1	48	532 18 11-56	Nut, Speed 5/16-18
22	532 17 93-71	Spacer, Engine Pulley	49	532 18 40-73	Frame Assembly
23	532 18 04-78	Pulley, Engine, Traction Drive	50	532 18 80-02	Plate, Frame End
24	532 17 91-57	Pulley, Engine, Impeller Drive	51	532 19 95-14	Shaft, Auger Control
25	532 06 27-35	Washer, Flat 3/8	52	532 05 70-79	Washer, Hardened
26	532 85 02-63	Washer, Lock, Helical 3/8	53	532 19 22-75	Roller
27	532 85 10-84	Screw, Hex Head 3/8-24 x 1-3/8	54	532 19 21-47	Ring, Crescent
28	532 15 54-52	Guide, Belt	55	812 00 00-02	E-Ring
			57	811 05 05-00	Washer, Lock, External Tooth 5/16
			58	532 18 38-54	Power Cord

**NOTE:** All component dimensions given in U.S. inches. 1 inch = 25.4 mm  
**IMPORTANT:** Use only Original Equipment Manufacturer (O.E.M.) replacement parts.  
Failure to do so could be hazardous, damage your lawn mower and void your warranty.

# REPAIR PARTS

# WHEELS / DECALS

SNOW THROWER - MODEL NO. **8527SBE** (96193000300), PRODUCT NO. 961 93 00-03

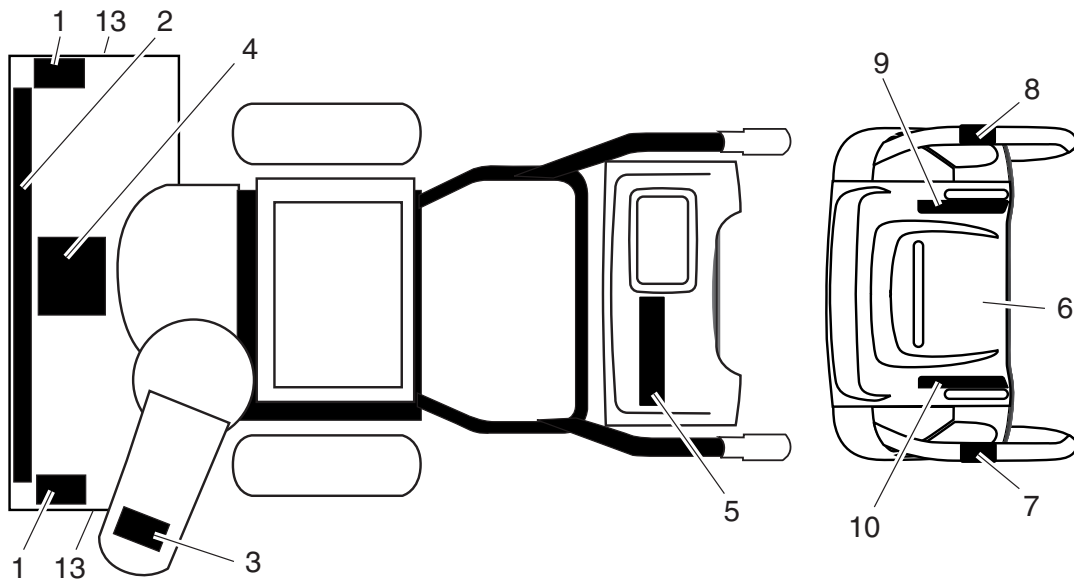
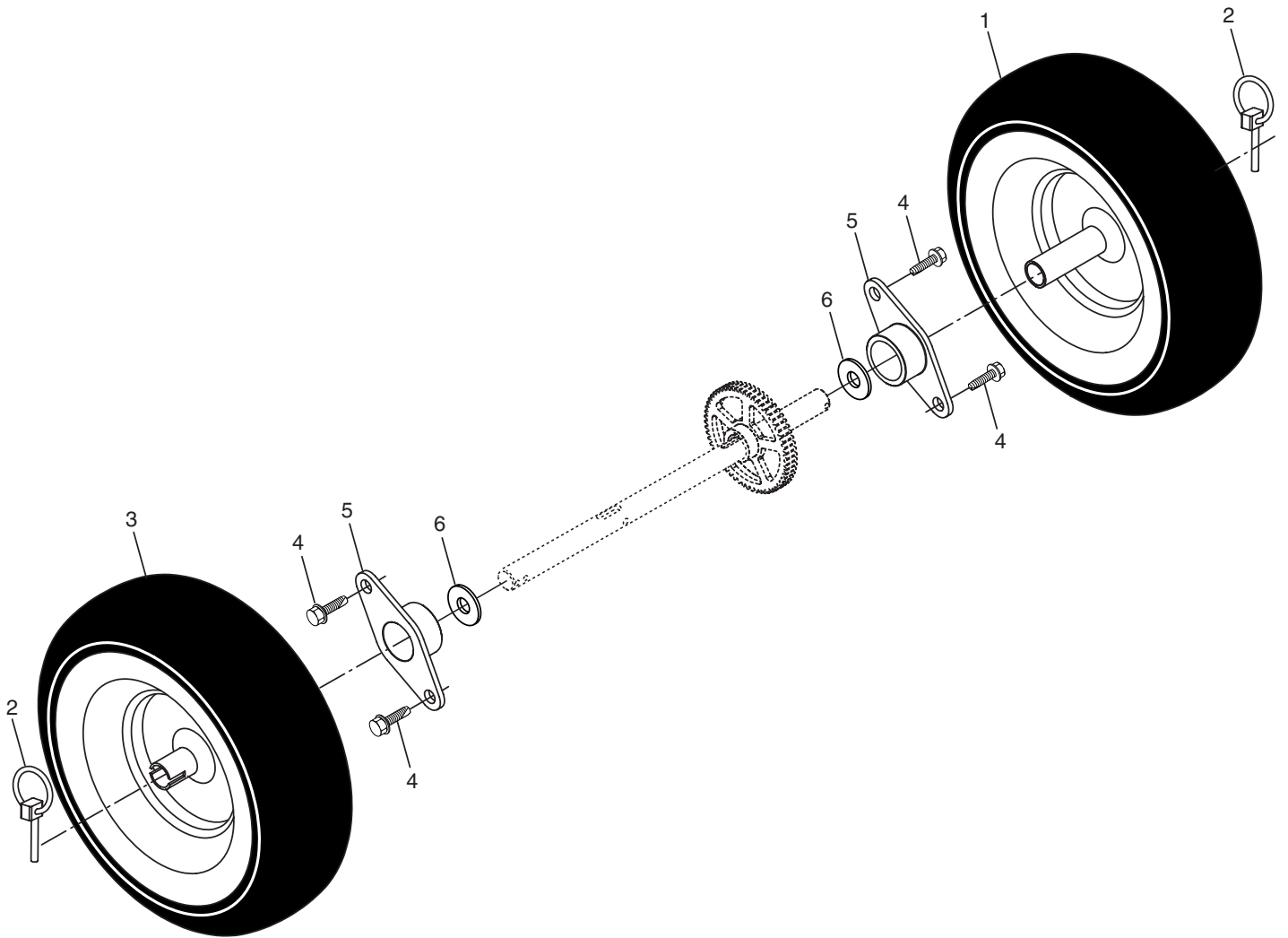

## REPAIR PARTS

## WHEELS / DECALS

SNOW THROWER - MODEL NO. **8527SBE** (96193000300), PRODUCT NO. 961 93 00-03

KEY NO.	PART NO.	DESCRIPTION
1	532 18 78-33	Wheel Assembly, 16", LH
2	532 15 54-43	Pin, Klik 1/4
3	532 18 78-65	Wheel Assembly, 16", RH
4	532 14 63-15	Screw, Hex Head 5/16-18 x 5/8
5	532 17 98-30	Bearing, Axle
6	532 17 46-97	Washer, Thrust (1")

KEY NO.	PART NO.	DESCRIPTION
1	532 18 10-38	Decal, Danger
2	532 19 13-76	Decal, Husqvarna
3	532 18 10-34	Decal, Danger, Deflector
4	532 18 10-41	Decal, Danger
5	532 19 85-89	Decal, Husqvarna, 8527SBE
6	532 18 10-32	Decal, Instruction
7	532 15 57-98	Decal, Traction Lever
8	532 15 58-00	Decal, Auger Lever
9	532 18 10-36	Decal, Speed Control
10	532 18 37-29	Decal, Remote Deflector
13	532 15 57-94	Decal, Husqvarna, Crown
--	532 19 83-79	Owner's Manual, English
--	<b>532 40 14-94</b>	Owner's Manual, French

**NOTE:** All component dimensions given in U.S. inches. 1 inch = 25.4 mm  
**IMPORTANT:** Use only Original Equipment Manufacturer (O.E.M.) replacement parts.  
Failure to do so could be hazardous, damage your lawn mower and void your warranty.