

PARTS MANUAL

Model

EH12-2

ENGINE

PUB-EP5713
Rev. 7/99

Robin America, Inc.

940 Lively Blvd. • Wood Dale, IL 60191 • Phone: 630-350-8200 • Fax: 630-350-8212
e-mail: sales@robinamerica.com • www.robinamerica.com

© Copyright 1999 Robin America, Inc.

HOW TO USE THIS MANUAL

Robin engines are identified by MODEL, SPECIFICATION, and CODE NUMBER. For each model there may be many different versions called specifications. Each specification will be unique in some way. The difference may only be the paint color or it may have a different type of PTO or some other significant difference.

In order to identify the correct service part number, it is important to confirm the specification and code numbers for your engine. The specification and code number together are known as the PRODUCT NUMBER.

All Robin 4 cycle engines have a Product Number label similar to the label illustrated below.

PRODUCT NUMBER LABEL



PRODUCT NUMBER LABEL LOCATIONS



The Product Number Label has a 15 digit alphanumeric string that consists of the SPECIFICATION (SPEC) number (11 digits) and the CODE number (4 digits). Please note the illustration below:

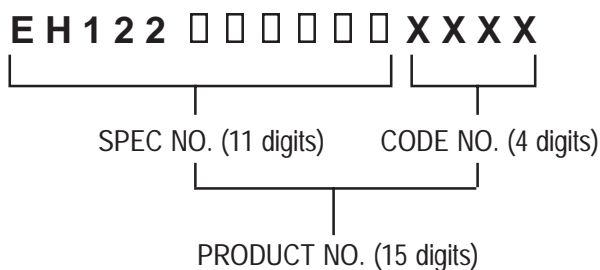

MANUAL LAYOUT

① — SECTION 6 **FUEL GROUP** **④**

② — FIG. 600

DETAIL A

① — SECTION 6 **FUEL GROUP** **⑥** **⑦** **⑨** **②**

REF.	PART NO.	DESCRIPTION	QTY	REMARKS	FROM-TO	FIG.
10	267-60103-01	FUEL TANK CP	1	YD, YS TYPE, BLACK	2101-	600
	267-60101-01	FUEL TANK CP	1	YELLOW	-2100	600
27	073-20039-00	LABEL, WARNING	1	YD, YS TYPE		600
30	043-04300-15	FUEL TANK CAP CP	1			600
31	267-95201-03	LABEL, EMISSION	1	YD, YS TYPE		600
40	064-13600-10	FUEL FILTER	1			600
50	064-20021-01	FUEL STRAINER AY	1			600
-1	064-20002-20	FILTER	1			600
-2	064-20002-30	GASKET	1			600
-3	064-20019-10	CUP	1			600
-4	064-20003-20	NUT	1			600

1. SECTION NAME Parts are broadly classified according to their functions. Refer to the Group Index (table of contents) for respective section name.
2. FIG. No. The FIG. number indexes the reference and part numbers to the illustration. Figure numbers that vary only in the tens place (i.e.: 700 and 710) are in a group of the same section (i.e.: Electrical Device Group).
3. REF. No. The Reference number identifies the part illustration with the corresponding part number in the part list.
4. SUBASSEMBLY SUBASSEMBLY parts of part assembly are listed below the assembly part. The subassembly part reference number is indicated by the number led by "-" such as "-1", "-2".
5. PART NUMBER It is the number assigned for sales unit. Use the PART No. when making an order.
6. DESCRIPTION It is designation of the part.
7. QTY. Quantity of each part used for each product.
8. REMARKS This gives a distinctive feature and/or a supplementary comment for the type, the specification, and the part concerned. It also shows part number(s) interchangeable for the part.
9. FROM-TO This section shows the CODE No. to indicate the history of progress in which improved parts have been introduced in the product. The FROM-TO CODE No. helps to identify PART No. being employed in the product concerned. See the examples below:
 - The part is used in the product irrespective of CODE No.
 - 2101- The part is used in the products with CODE No. of 2101 and after this number.
 - 2100 The part is used in the products with CODE No. of 2100 and before this number.

GROUP INDEX

Group Name	Page
CRANKCASE GROUP	6
CRANKSHAFT GROUP	8
INTAKE and EXHAUST GROUP	10
GOVERNOR GROUP	12
COOLING and STARTING GROUP	14
FUEL GROUP	16
CARBURETOR	18
ELECTRIC DEVICE GROUP - RECOIL START	20
ELECTRIC DEVICE GROUP - ELECTRIC START	22
ELECTRIC DEVICE GROUP - ELECTRIC STARTER	24
ELECTRIC DEVICE GROUP - OIL SENSOR	26

INDEX OF DESCRIPTION SYMBOLS			
SYMBOL	DESCRIPTION	SYMBOL	DESCRIPTION
AY	ASSEMBLY	P=	PITCH (in mm)
CP	COMPLETE	P.T.O. (PTO)	POWER TAKE OFF
EX	EXPORT (from Japan)	REF.	REFERENCE
FIG.	FIGURE	R.H. (RH)	RIGHT HAND SIDE
FR.	FRONT	RR.	REAR
"	INCH	STD.	STANDARD
INCL.	INCLUDE	SW	SWITCH
~L	LITER	T=	THICKNESS (in mm)
L=	LENGTH (in. mm)	UN	UNIT
L.H. (LH)	LEFT-HAND SIDE	U.S.	UNDER SIZE
MECH	MECHANICAL	~V	VOLTAGE
NO (NON)	NONE	~W	WATT
OPT.	OPTIONAL	W/	WITH
O.S.	OVER SIZE	W/O	WITHOUT

SECTION 1 CRANKCASE GROUP

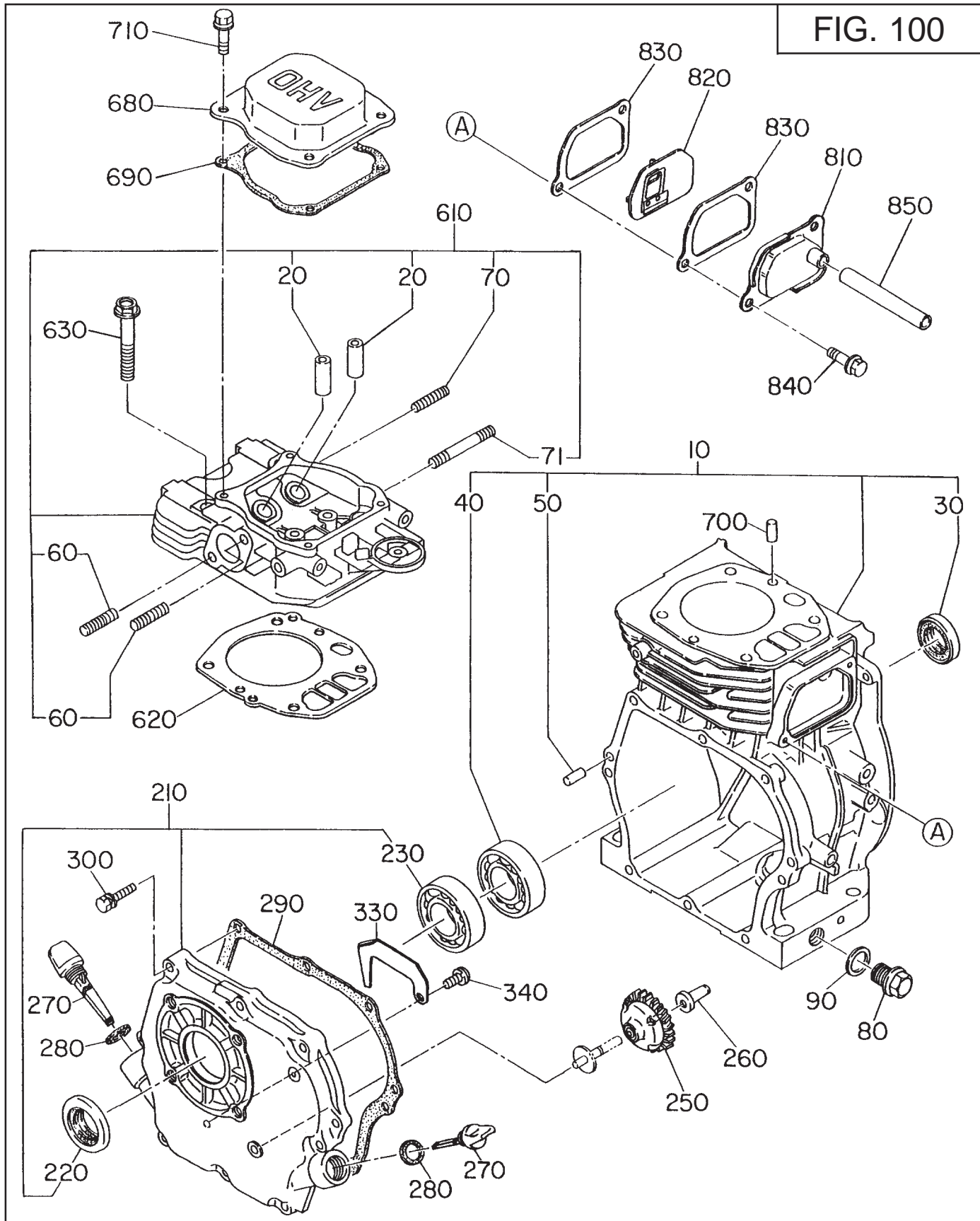

SECTION 2 CRANKSHAFT GROUP

FIG. 200

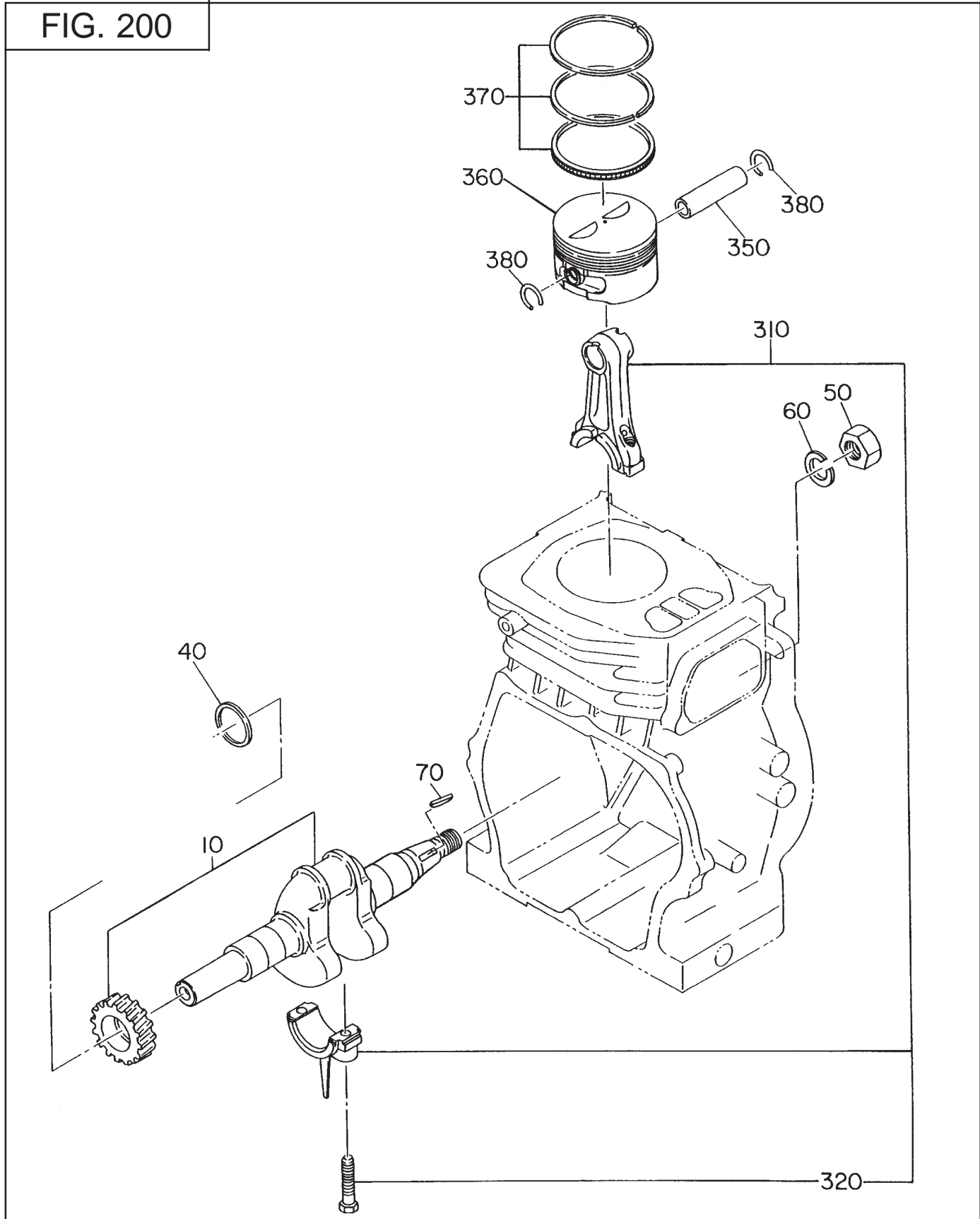

SECTION 3 INTAKE and EXHAUST GROUP

FIG. 300

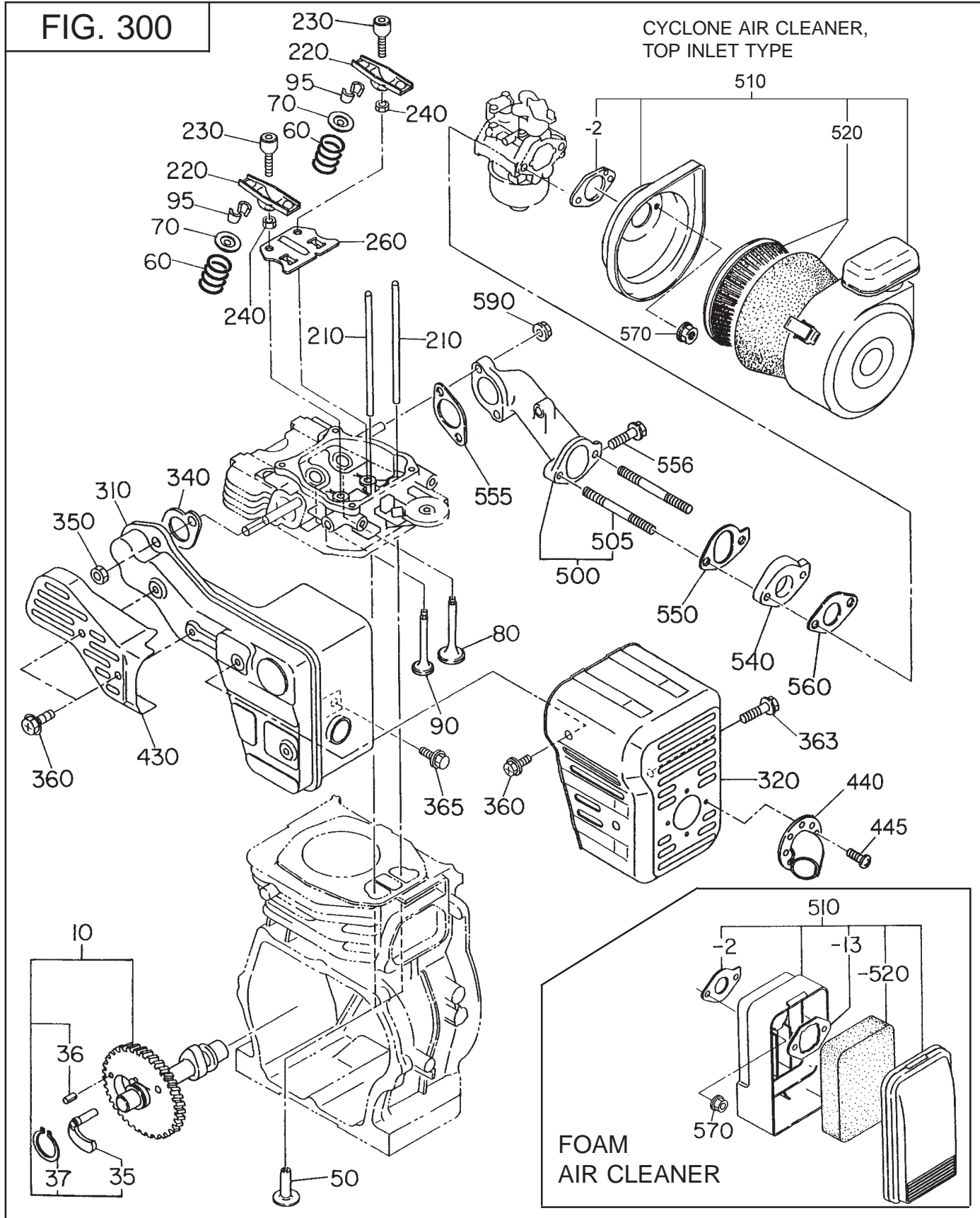

SECTION 3 INTAKE and EXHAUST GROUP

REF.	PART NO.	DESCRIPTION	QTY.	REMARKS	FROM-TO	FIG.
10	253-31701-11	CAMSHAFT CP	1			300
35	227-36401-03	RELEASE LEVER	1			300
36	005-19041-00	SPRING PIN	1			300
37	003-15220-00	SNAP RING	1			300
50	239-33301-13	TAPPET	2			300
60	253-33601-03	VALVE SPRING	2			300
70	132-09KA0-40	SPRING RETAINER	2			300
80	268-33401-03	INTAKE VALVE	1			300
90	268-33501-03	EXHAUST VALVE	1			300
95	132-10KA0-31	COLLET VALVE	4			300
210	268-35301-03	PUSH ROD	2			300
220	261-36001-A3	ROCKER ARM	2			300
230	269-35801-03	BOLT, PIVOT	2			300
240	017-00600-90	NUT	2			300
260	269-36501-03	GUIDE PLATE	1			300
310	268-30101-01	MUFFLER CP	1			300
320	253-34201-11	MUFFLER COVER	1			300
340	253-35201-03	GASKET, MUFFLER	1			300
350	017-00800-30	NUT	2			300
360	015-20600-90	TAPPING BOLT	4			300
363	015-20601-00	TAPPING BOLT	1			300
365	011-00600-20	FLANGE BOLT	1			300
430	269-34801-03	EXHAUST PIPE COVER	1			300
440	236-37001-01	DEFLECTOR, EXHAUST	1			300
445	015-00400-10	TAPPING SCREW	2			300
500	253-33001-01	INTAKE PIPE CP	1			300
505	010-50602-30	STUD	2			300
510	252-32612-10	AIR CLEANER AY	1	CYCLONE top inlet type		300
-2	236-32630-08	PACKING	1	CYCLONE top inlet type		300
510	269-32601-00	AIR CLEANER AY	1	FOAM AIR CLEANER type		300
-2	227-36004-13	PACKING	1	FOAM AIR CLEANER type		300
-13	269-32651-08	PLATE	1	FOAM AIR CLEANER type		300
-520	269-32610-08	AIR CLEANER ELEMENT	1	FOAM AIR CLEANER type		300
520	226-32610-07	ELEMENT SET	1	CYCLONE top inlet type		300
540	253-32901-03	INSULATOR	1			300
550	253-35901-03	GASKET 3, INSULATOR	1			300
555	227-35901-03	GASKET, INSULATOR	1			300
556	011-00601-30	FLANGE BOLT	1			300
560	236-35903-03	GASKET 2, INSULATOR	1			300
570	226-39212-00	NUT AND WASHER AY	2	CYCLONE top inlet type		300
	002-38060-00	FLANGE NUT	2	FOAM AIR CLEANER type		300
590	002-38060-00	FLANGE NUT	2			300

SECTION 4 GOVERNOR GROUP

FIG. 400

MANUAL THROTTLE CONTROL with REMOTE CABLE OPTION

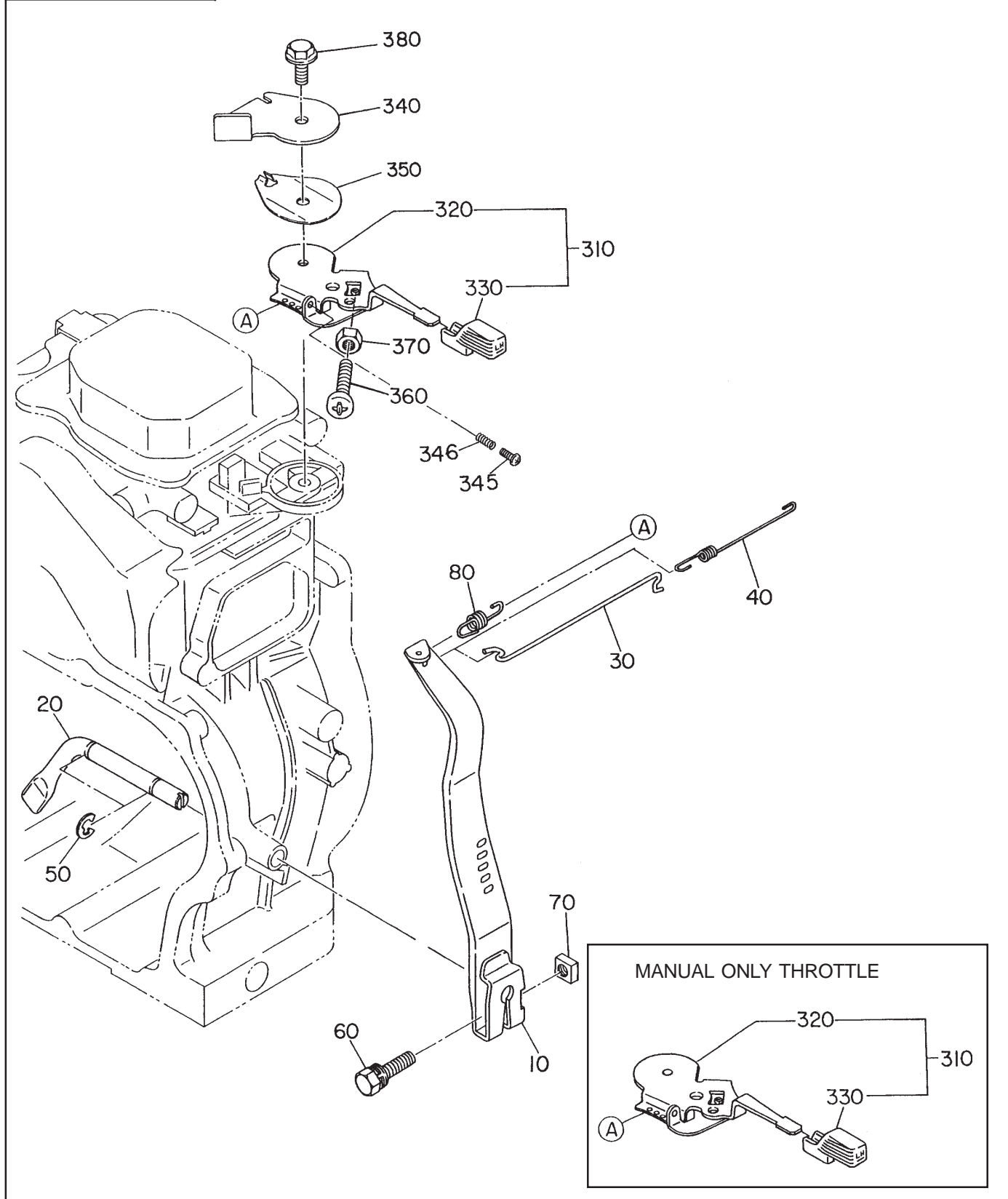

SECTION 5 COOLING and STARTING GROUP

FIG. 500

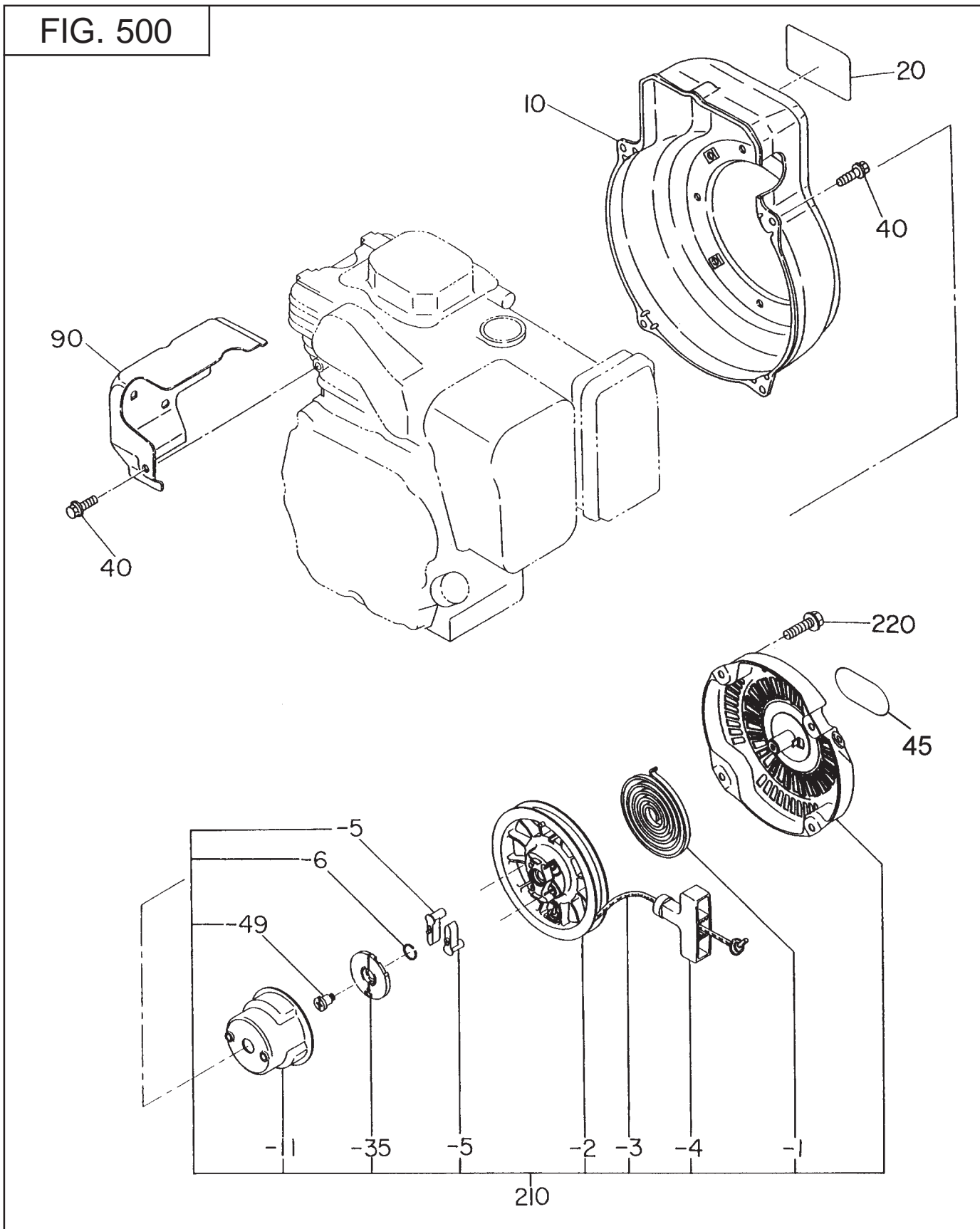

SECTION 6 FUEL GROUP

FIG. 600

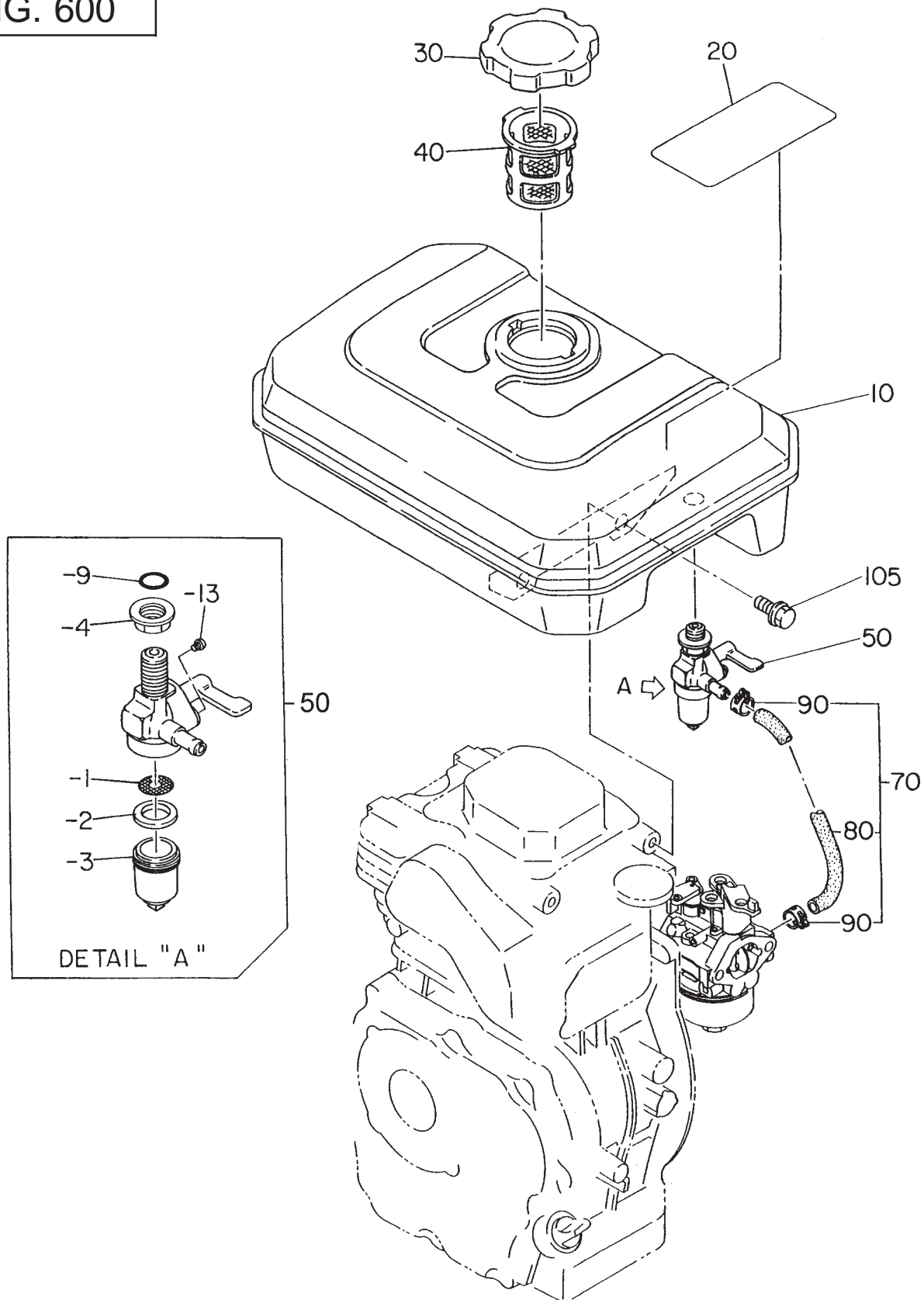
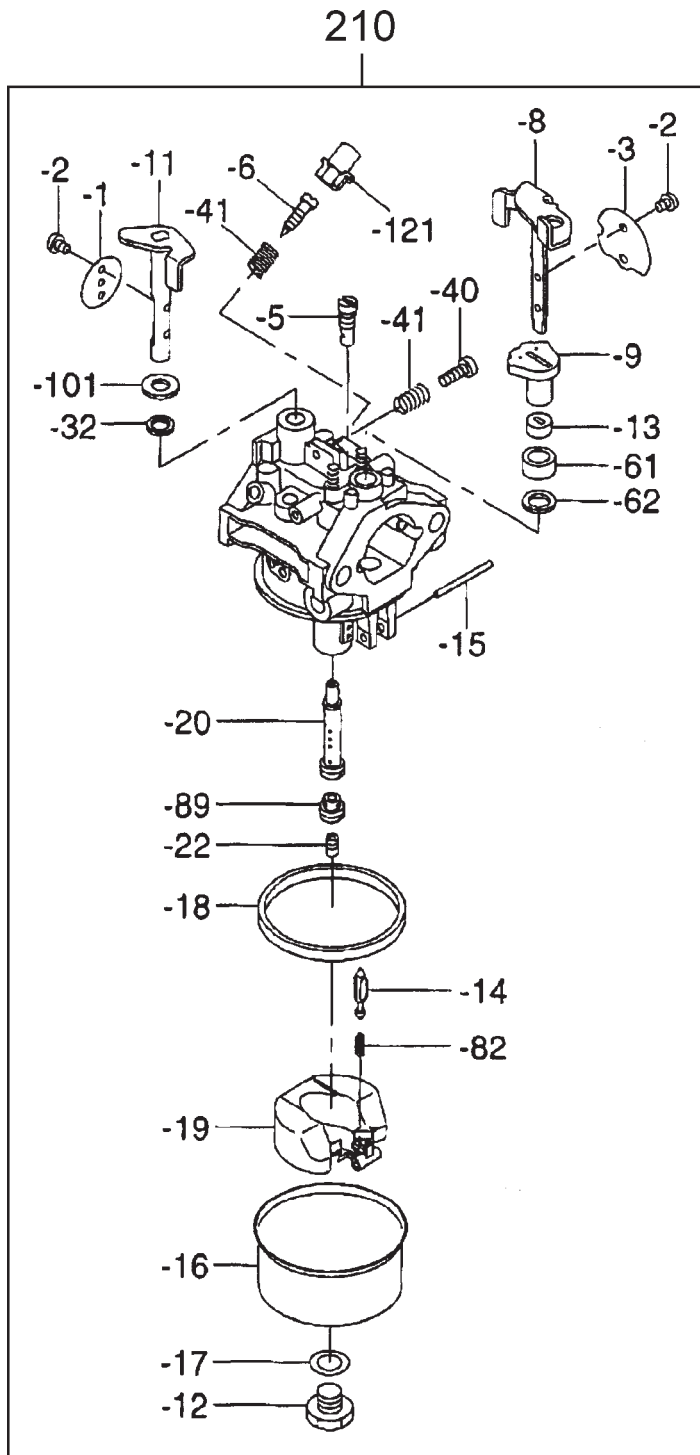
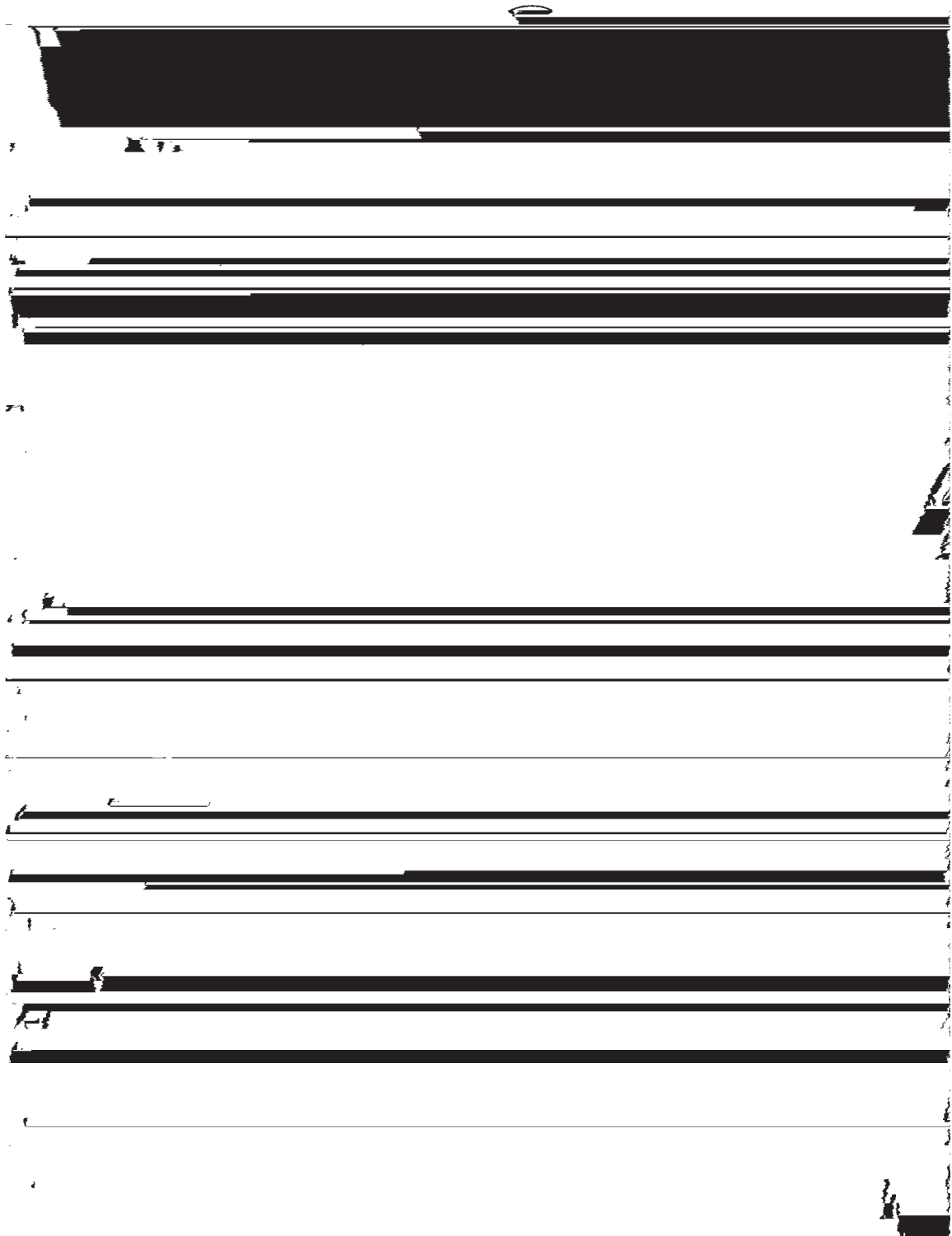

FIG. 610



SECTION 7A ELECTRIC DEVICE GROUP - RECOIL START

FIG. 700



SECTION 7D ELECTRIC DEVICE GROUP - OIL SENSOR

FIG. 760

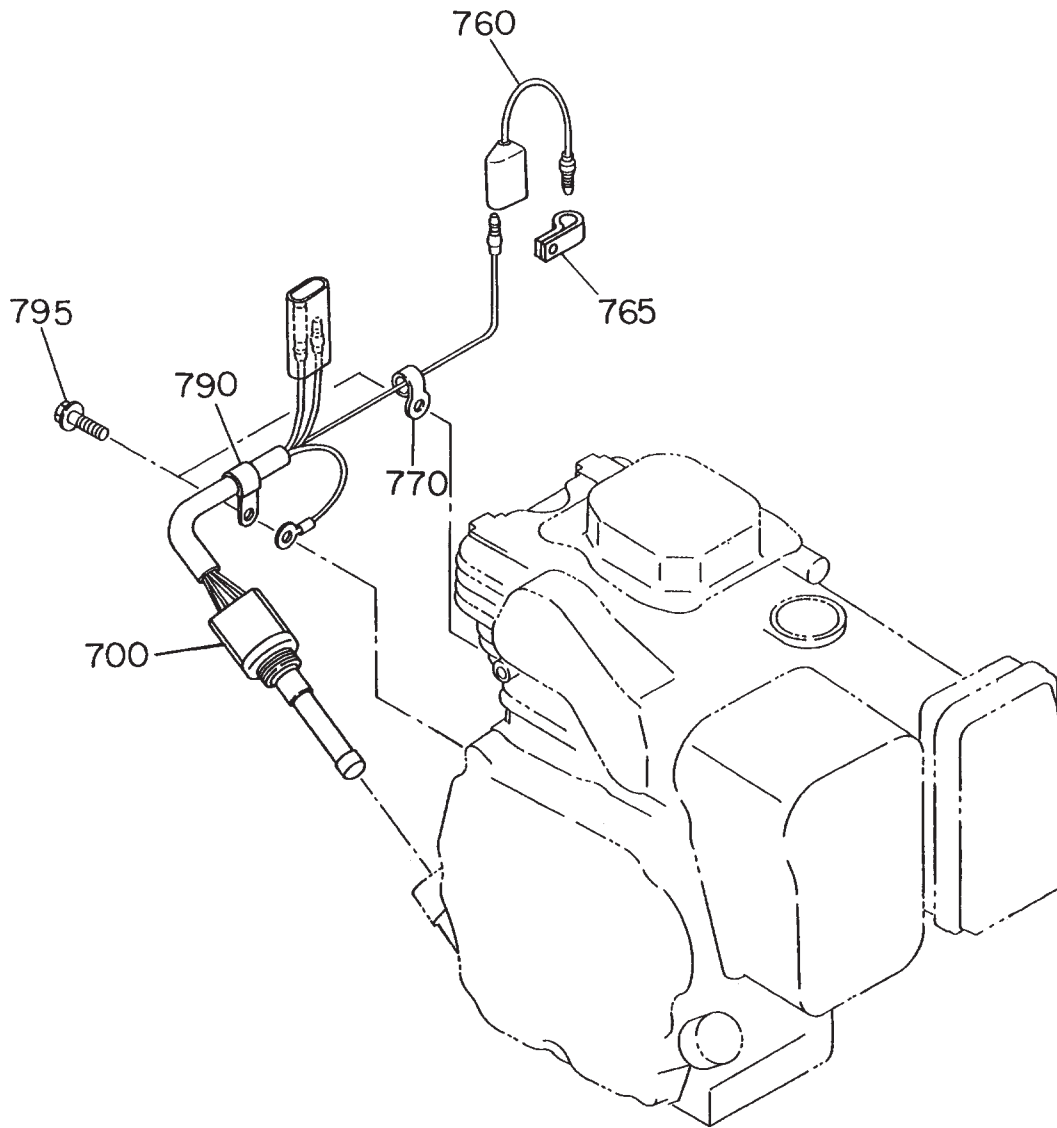

PRINTED IN THE USA